

FORGED STEEL VALVE USER GUIDE

BB – OS & Y TYPE

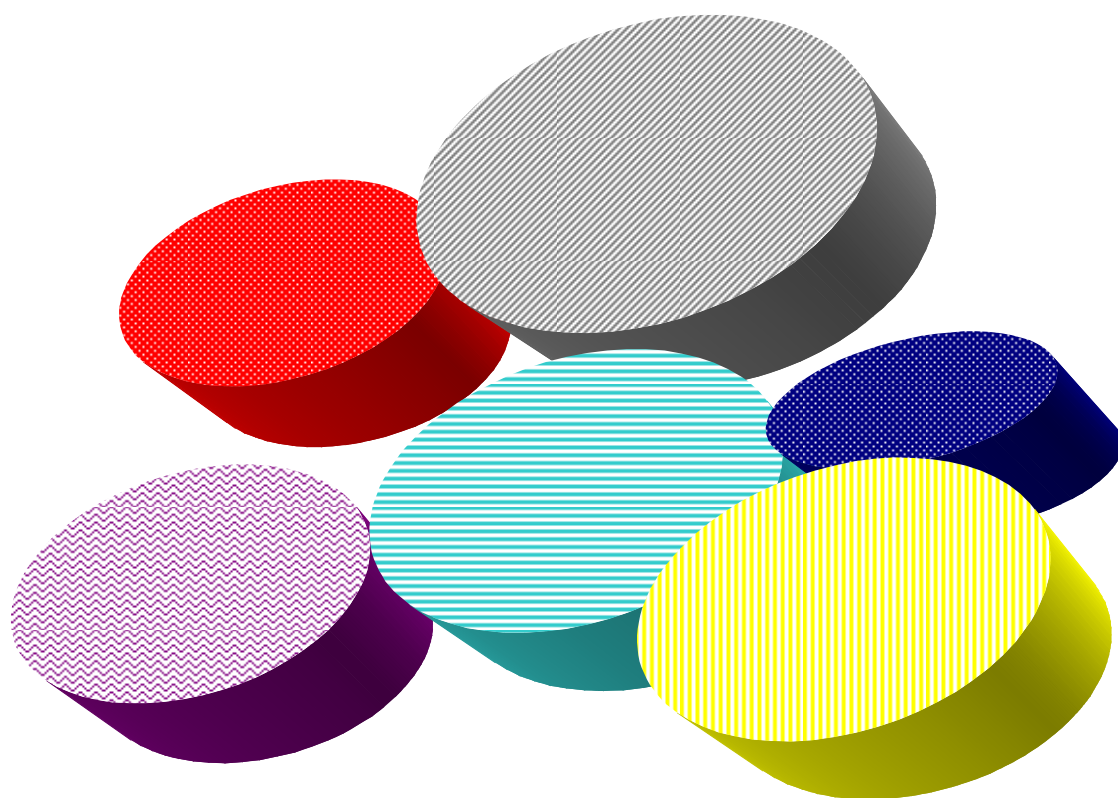

SHORITSU SEISAKUSHO CO., LTD.

Cover designed by Mr. Mitsuo Nakane

- Cover design is the sketch of the image of aboveground tanks in industrial complex.

FOREWORD

Thank you really for purchasing our valves. Read this valve user guide thoroughly to use our valve properly. Keep this valve user guide in the place where handling person can use immediately.

REQUEST

- As for your inconvenience, which occurred by the mentioned items of this valve, user guide weren't observed, and please consent in advance because our company is hardly responsible.
- Please contact the following our Sales Department if there are unclear and noticeable points, though we made and expected with assurance about the contents of this valve user guide.
- For the details of specifications and parts of product, please refer to the assembly drawings with respective valve.

SHORITSU SEISAKUSHO CO., LTD.

Head Office and Sales Department

7-21, Matsushima 2-Chome, Edogawa-Ku, Tokyo 132-0031, Japan

Tel.: 81-3-3654-9211, Fax: 81-3-3651-5688

E-mail: shoritsu@sfv.co.jp

This valve user guide covers gate valve with BB-OS&Y type, globe valve with BB-OS&Y type, and check valve with BC type.

Safety Notice and Signs

When handling of valve is improper, the harm and the damage will be occurred. The degree of the harm and the damage is classified in the "Warning" and the "Caution" indications, and the contents of the indication throughout this valve user guide are as follow.



Indicates a potentially hazardous situation, which could result in death or serious injury if you do not follow instructions.



Indicates a potentially hazardous situation, which if not avoided, may result in minor injury or property damage.

Be sure to KEEP it because they are important contents about the safety.

CONTENTS

SECTION	PAGE
1. STRUCTURE AND FUNCTION	
Gate Valve	6
Globe Valve	10
Check Valve	14
2. INSTALLATION	17
3. SHIPPING, UNPACKING AND STORAGE	18
4. HANDLING AND OPERATION	20
5. ROUTINE INSPECTION	23
6. DISASSEMBLING AND ASSEMBLING	
Gate Valve	27
Globe Valve	32
Check Valve	35
7. TROUBLESHOOTING GUIDE	38
8. NAME PLATE SPECIFICATION	40
9. GUARANTEE	43
10. NECESSARY TOOLS	44

Section 1

STRUCTURE AND FUNCTION

1. Gate Valve

■ Structure

The names of each part and the structure are as shown in the Figures 1.1 & 1.2.

■ Function

- Mainly, gate valve is used for the cutting-off the fluid.
- To open and close the gate valve, the valve stem and disc shall be up and down by rotating the hand wheel. Clockwise rotation of the hand wheel shall close the gate valve. Counter-clockwise rotation of the hand wheel shall open the gate valve.
- When gate valve is in fully open position, the pressure loss of gate valve is little in comparison with globe valve.
- Do not use gate valve in half-opened position. If used, there will occur turbulent at the back of valve disc and resistance of flow becomes large and will occur vibration and corrosion of valve disc.
- Especially, there is no direction against the fluid flow except for some valves.

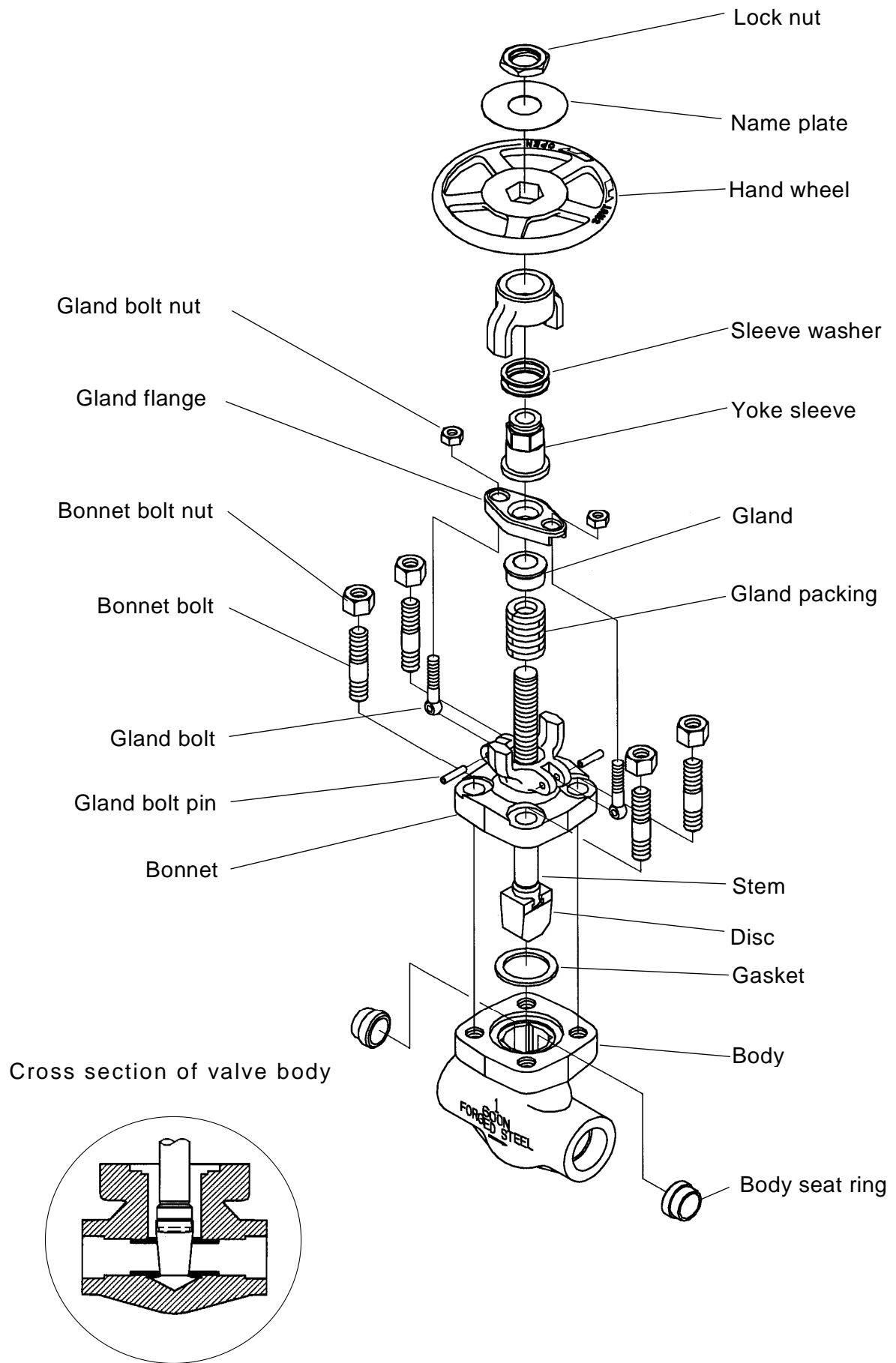

Figure 1.1 Typical Examples for Class 600 Gate Valve

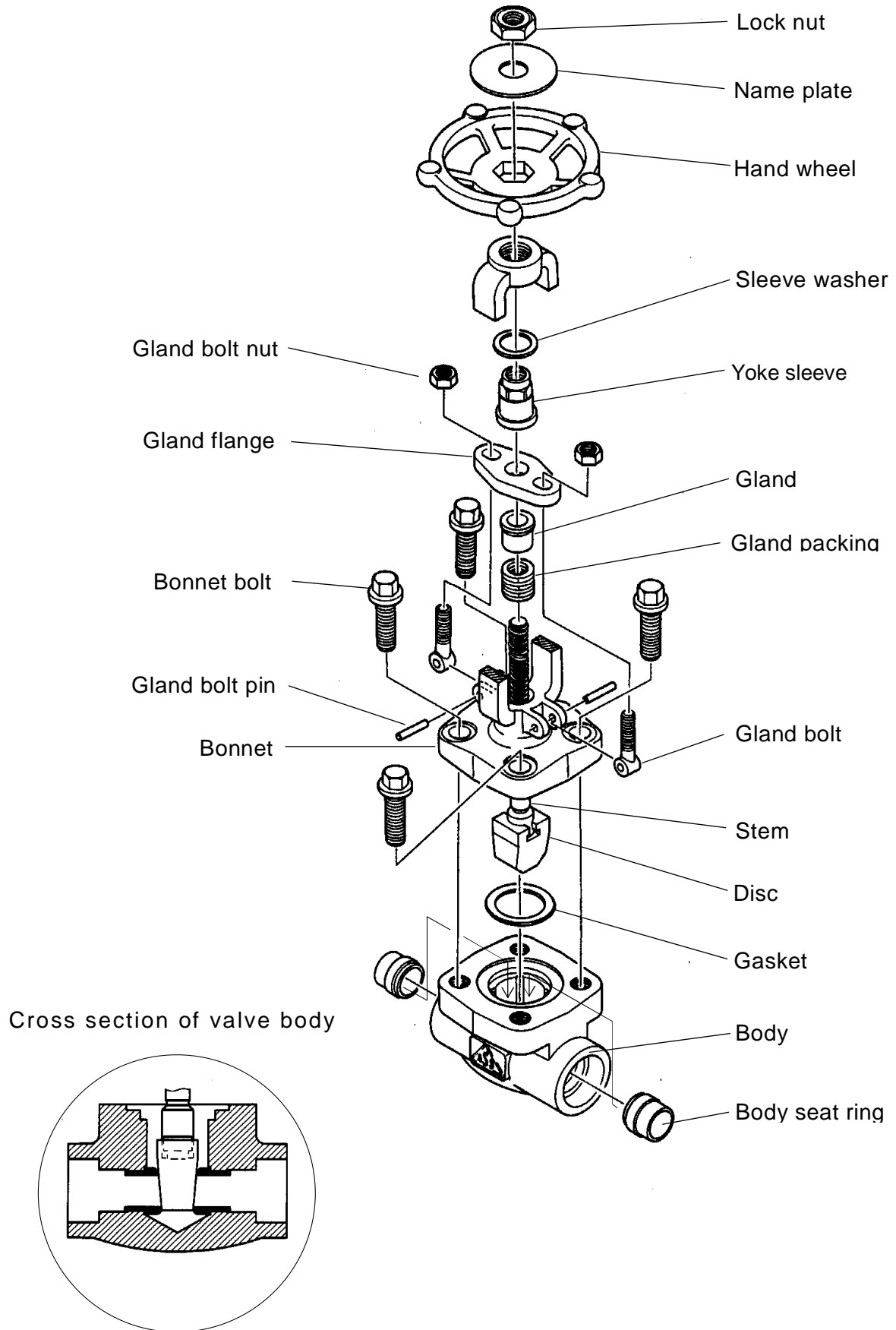

Figure 1.2 Typical Examples for Class 800 Gate Valve

THIS PAGE IS BLANK INTENTIONALLY.

Section 1

STRUCTURE AND FUNCTION

2. Globe Valve

■ Structure

The names of each part and the structure are as shown in Figures 1.3 & 1.4.

■ Function

- To open and close the globe valve, the valve stem shall be up and down by rotating the hand wheel. Clockwise rotation of the hand wheel shall close the globe valve. Counter-clockwise rotation of the hand wheel shall open the globe valve.
- The centerline of inlet and outlet of valve is in the straight line and the flow of fluid is S letter-shaped. Globe valve has high shut-off efficiency due to the closure the valve disc against the flow of the fluid.
- The quantity of flow and fluid pressure can be adjusted by using the globe valve under the condition of halfway open position.
- The flow direction shall be one direction.

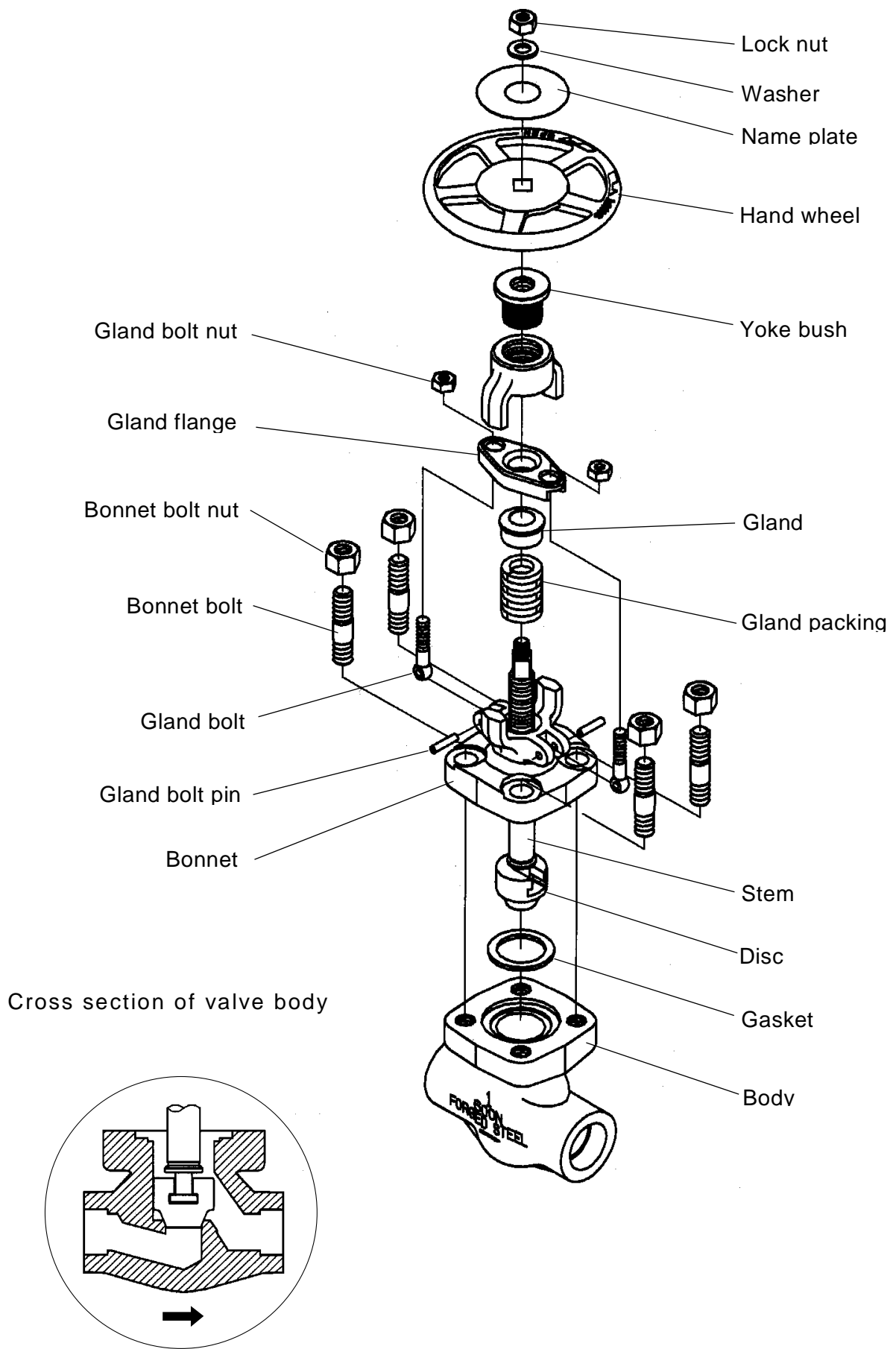

Figure 1.3 Typical Examples for Class 600 Globe Valve

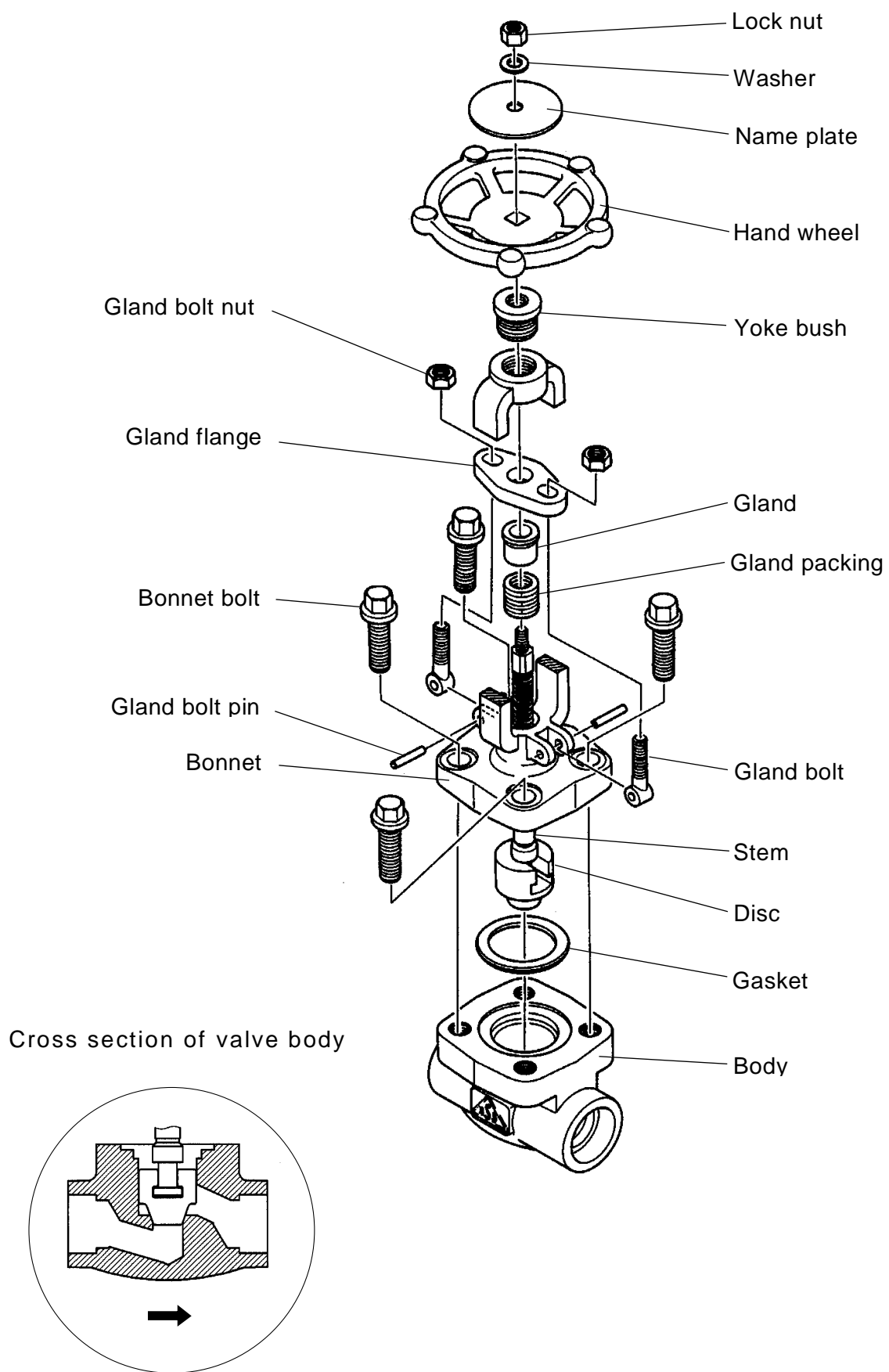

Figure 1.4 Typical Examples for Class 800 Globe Valve

THIS PAGE IS BLANK INTENTIONALLY.

Section 1

STRUCTURE AND FUNCTION

3. Check Valve

■ Structure

The names of each part and the structure are as shown in Figures 1.5 & 1.6.

■ Function

- The opening of check valve is due to the pressure of flowing fluid against the weight of disc. The closing of check valve is due to own weight of disc.
- Check valves shall be installed in the horizontal pipeline so that valve disc moves vertically by valve guide in valve body. Don't install it in the vertical pipeline.
- Allow for only one direction of the fluid flow, and design for the purpose of preventing the reversed flow.
- Be careful the check valve in low flow velocity because chattering (Note 1) is easy to cause.
- Please consult before you order when the difference pressure between inlet and outlet of valve is little.

Note 1: Chattering means the phenomenon that a valve disc strikes a valve seat repeatedly when the valve is in slight-open position.

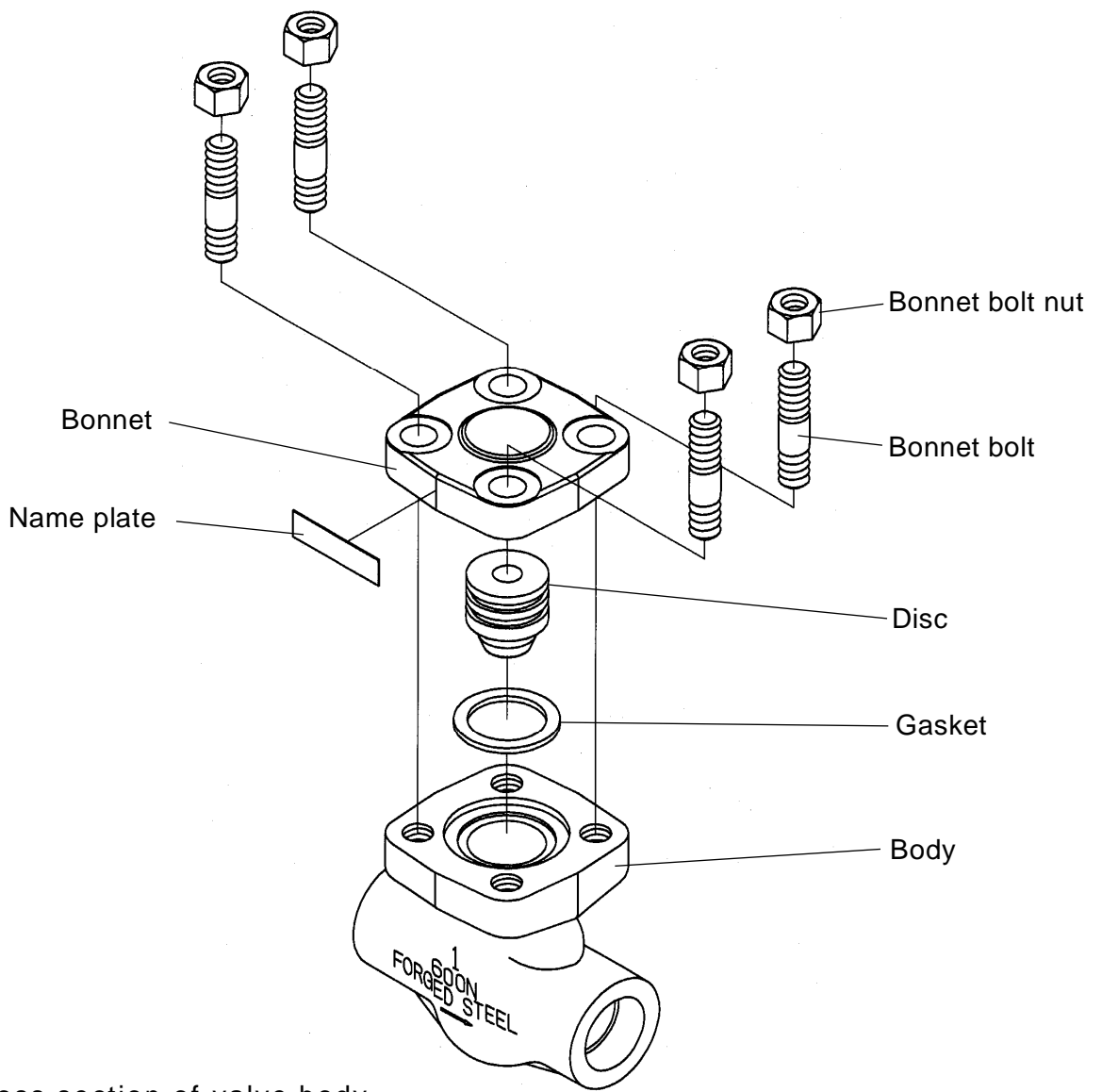

Cross section of valve body

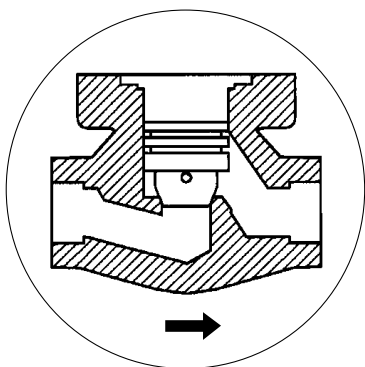

Figure 1.5 Typical Examples for Class 600 Check Valve

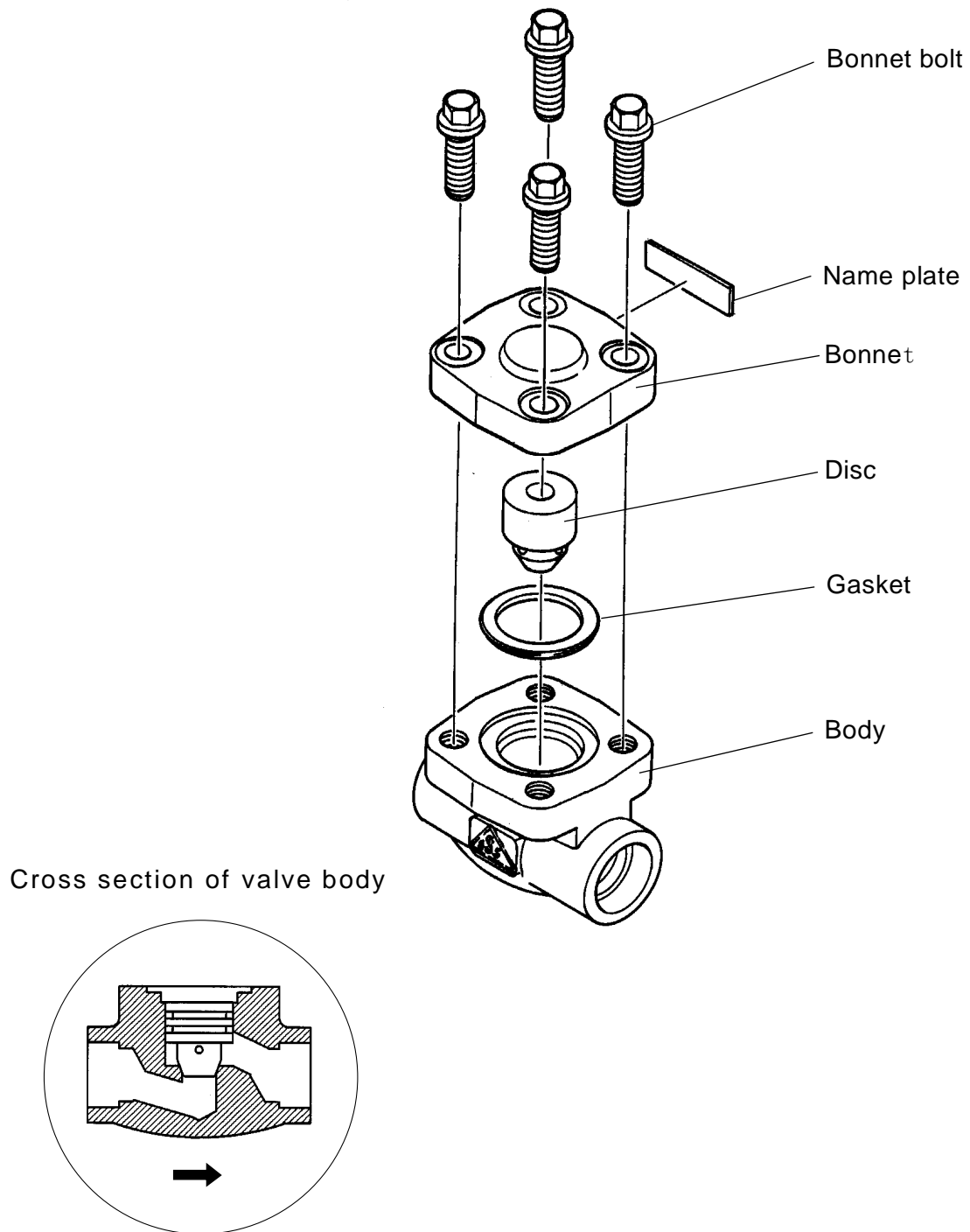

Figure 1.6 Typical Examples for Class 800 Check Valve

Section 2 INSTALLATION

■ Caution to Installation of Valve



CAUTION

- Hand wheel, gland and stem should not be used as lifting points, when hanging the valve.
- For safety, do not allow entering any people under hanging load, when hanging the valve.
- Do not use the hand wheel of valve as a foothold. It may cause damage the valve.
- Perform the work after securing the surrounding safety.

■ About Installation

- When weld the socket-welding end valves into pipeline, care must be taken to ensure that welded valves shall be in slightly open position.
- As the construction of the gate valve has nothing to do with the direction of flow, either of the inlet port or the outlet port can be joined to the pipeline regardless of the direction of flow. However, the globe valve is sensitive to the direction of flow because it is designed to flow of fluid from the downstream side of valve disc. If the outlet port and the inlet port are connected wrongly, these valves will not function properly. (Note 1)
- Install the check valve in accordance with the arrow mark of the flow direction on the body. (Note 2)

(Note 1) If the globe valve is installed in wrong direction, the deterioration of gland packing has become quickly in normally closed position. In normally open position, the corrosion may occur at the connection of valve stem and valve disc. Please consult our company, if the globe valve will be installed the opposite direction of the arrow mark of flow direction. Globe valve shall be designed, produced and inspected in accordance with your requirements.

(Note 2) If it isn't installed as indicated flow direction, the function of back flow prevention can't be fulfilled. And, the fluid doesn't flow even through proper flow.

Section 3 SHIPPING, UNPACKING, AND STORAGE

■ Caution to Shipping



CAUTION

- Be careful the handling of product packed in corrugated cardboard when it is wet in the water, the strength of corrugated cardboard is declined, and packing is broken, and the product will be damaged.
- Do not allow entering any people under the load during transfer and shipment of valve with hoist and hook.
- Do not load under unstable condition.
- Handle the valve carefully during unloading.

■ Caution to Unpacking



CAUTION

- Confirm the weight of valve, and do not allow entering any people under the load during raising the valve.
- Do not shock the valve due to the drop, the turnover, and so on.

■ About Unpacking

- Confirm the contents of the package of valve by the shipping instruction.
- The kind of valve, the material of valve body and bonnet, trim material, nominal pressure and nominal diameter of valve shall be confirmed by name plate, which attached on the hand wheel of the valve.
- Please refer to “Section 8, NAME PLATE SPECIFICATION” for how to read the name plate.

■ Caution to Storage of Valves



CAUTION

- The polyethylene caps on the inlet and outlet end of valves shall not be removed until immediately prior to valve installation. It may cause damage to valve seat when the entering of the foreign materials within the metal touch of valve seats.
- The valves shall not be kept outdoors or in humid and dusty places. They shall be kept indoors, well-ventilated places.
- Coat rust preventives again to the inside and outside of the valve when keeping it in the period any further because coating effect declines when it passes through three months, though rust preventives is applied to the inside and outside of the valve.
- To avoid keeping it on the ground floors or the concrete floor directly, and to keep away from the moisture by placing them on adequate blocks or sleepers.

Section 4

HANDLING AND OPERATION

1. Handling

■ Caution about Valve Handling



CAUTION

- Do not use gate valve at a half opened position. The gate valve can be damaged because the repetitive collision or impact force of the fluid is given to valve body and valve stem, and, consequently, vibration may be occurred.
- Do not apply the excessive force and impact force in the opening and closing operation of the valve. The function of the valve is likely to be spoilt.
- Handle the valve gradually so that water hammer may not occur and confirming that there is no vibration, noise and leakage in the valve.

■ Handling of Valve

- Valves can be opened and closed by turning the hand wheel to the direction of “O” and “S” markings on it, respectively. After valves are fully opened or closed, they shall not be additionally opened or closed by using auxiliary levers such as the wrench. Additional opening or closing may cause damage to seat surfaces. The gate valve shall be used at the full open position or the full close position, and it shall not be used at a half-opened position. In that case, valve disc becomes under unstable condition, and valve may cause damage due to the force of fluid flow.
- When the valve cannot close fully, open the valve first, and then close it. It is possible that owing to foreign matters such as scale, which has come into the seat surface, the valve does not close. In such cases, open the valve and blow the foreign matters off. If the valve can not still close satisfactorily, repeat the above operation several times.
- When the valve is put into services, it is necessary to adjust the tightness to the gland packing by tightening the gland bolt nut. For increasing the tightness, care must be given so that the tightening force should be added evenly. Too much tightening may cause the trouble to movement of the hand wheel. Tighten the gland packing adequately so as to stop the leak of the fluid.
- For the valves, which are not closed or opened frequently, apply grease periodically to the stem thread. Although the stem is made of the rust resistant material, it is still necessary to protect the stem against rusting. Lubrication is required also for smooth operation of the valves.

2. Operation

■ Caution about Valve Operation



CAUTION

- Do not loosen lock nut of hand wheel, gland bolt nuts and bonnet bolt nuts while the valve is under pressure.
- Take the measures of prevention of freezing when freezing of valve is predicted.

3. Daily Inspection

■ About Daily Inspection

Daily inspections are important to find out the signs of abnormal conditions of the operating valve in advance and to take measure the stoppage of operation. Daily inspections items in the valve operating condition is as follows;

Condition	Type of Valve	Portion to be checked	Inspection Method	Troubleshooting in abnormal
Leakage to the outside of valve	Common	At the flange	Visual Soap water	• Tightening up the bolt
		Surface of valve	Visual Soap water	• Replace the whole valve
		Thread in Connection	Visual Soap water	• Tightening up at the connection of thread • Replace the relative parts • Replace bolts and nuts
	Gate valve Globe valve	At the gland	Visual Soap water	• Tightening up the eye bolt nuts • Replace the relative parts
Abnormal noise	Common	The whole valve	Listening	• Contact the responsible person and department, and troubleshooting
Defective appearance	Gate valve Globe valve	Hand wheel	Visual	• Replace when the hand-wheel is damaged
	Common	The whole valve	Visual	• Apply rust preventive after removal of rust when rust occurs.
Improper motion	Common	Movable parts	Touch by fingers	• Apply grease on the movable parts, however, oxygen service valve is coated only grease for oxygen service.

Section 5

ROUTINE INSPECTION

■ About Routine Inspection

- Perform the routine inspection of the valve once in one year at least under the installed condition.
- Confirm the condition of valve that it is under smooth operation and there is no hindrance of safety.

■ Inspection when Disassembling

Perform valve leakage test, operation test, disassembling inspection, and so on if necessary when the equipment that a valve was installed is opened for the inspection of public safety. Perform disassembling inspection and necessary troubleshooting when there are leakage inside of the valve, inferior operation, imperfect function, and so on.

■ Caution to Disassembling Valve



WARNING

- Disassemble the valve carefully and slowly, after confirming that the pressure in pipeline falls down completely and there is no remaining pressure inside of the valve and pipeline.
- Be sure to wear safety belt on your waist when dismantling work. Tie up the safety belt without fail when dismantling work in elevation.
- Be careful the safety of work and take the measures that no permit to enter under working.



CAUTION

- Perform the work by person who learned sufficient skill and technical knowledge.
- Perform the work with protection guards (protection glasses, gloves for the work, safety shoes).
- Use suitable tools properly.

■ Disassembling

Refer to “Section 6, DISASSEMBLING AND ASSEMBLING” for disassembling the valve.

■ Inspection Items when Disassembling

Method of the inspection and troubleshooting for the valve defects are as follows.

Name of Part	Kind of Valve	Portion to be Inspected	Inspection Method	Criterion	Troubleshooting
Valve body	Common	Seat surface	Visual Inspection	No corrosion, No crack	Replace
				No damage	Lapping the seat surface
			PT inspection	No crack, No pinhole	Replace
		Inside surface	Visual Inspection	No foreign materials	Cleaning and air-blow the inside surface
Valve bonnet	Gate valve and globe valve	Stuffing box	Visual Inspection	No corrosion, No damage	Replace
Valve disc	Common	Surface	Visual Inspection	No damage	Machining after stellite welded and change
		Contact surface	Visual Inspection	Good lapping	Machining after stellite welded and change
	Gate valve and globe valve	Valve disc and stem and relative part	Visual Inspection	No corrosion, No wear	Replace
	Check valve	Operability	Touch by fingers	Smooth operability	Cleaning

Name of Part	Kind of Valve	Portion to be Inspected	Inspection Method	Criterion	Trouble-shooting
Valve Stem	Gate valve	Valve stem, disc and relative parts	Visual Inspection	No corrosion, No wear	Replace
		Screw parts	Visual Inspection	No rupture No damage No wear	Replace
		Outside surface	Visual Inspection	No corrosion, No wear No bending	Replace
		Shape	Visual Inspection	No bending No damage in threads	Replace
Yoke sleeve and yoke bush	Gate valve globe	Valve stem and moving face	Touch by fingers	Smooth operation	Apply grease
		Screw parts	Visual Inspection	No wear	Replace
		Flange parts	Visual Inspection	No crack, No bending	Replace
Gland packing	Gate valve globe	The whole	Visual Inspection	—	Replace
Gasket	Common	The whole	Visual Inspection	—	Replace
Gland and gland flange	Gate valve globe	The face of gland	Visual Inspection	No damage, No crack, No bending	Replace

■ Assembling

Refer to "Section 6, DISASSEMBLING AND ASSEMBLING" for assembling the valve.

Section 6

DISASSEMBLING AND ASSEMBLING

1. Gate Valves

■ Disassembling Procedure

Since all valves have been correctly assembled and tested, an easy-going disassembling of valves should be avoided.

● Caution to Disassembling Valve



WARNING

- Disassemble the valve carefully and gradually, after confirming that the pressure in pipeline falls down completely and there is no remaining pressure inside of the valve and pipeline.



CAUTION

- Perform the work by person who learned sufficient skill and technical knowledge.
- Perform the work with protection guards (protection glasses, gloves for the work, safety shoes).
- Use suitable tools properly.

■ Before Disassembling

- Keep necessary lighting in the disassembling workshop.
- Perform disassembling in the workshop where there is no vibration, no dust and no moisture.
- Make the match mark on the body-bonnet joint by marking pen as shown in Figure. 6.1 before loosening the bonnet bolts. When assemble the valve, body and bonnet shall be fitted by match mark.

■ Disassembling

- 1) Turn the hand wheel of the fully closed valve to the left to obtain an intermediate valve opening. Since the body seat rings and disc of the closed gate valve are in close contact, it is difficult to disassemble the valve as it is. Therefore, it is necessary to open such valve to an intermediate position so it makes disassembling easier.

- 2) Remove four bonnet bolts in diagonal line by turning them to counter-clockwise under the condition as it is. If there is remaining pressure inside the valve, there is leakage together with the escaping sound at this moment. Leave the disassembling valve until the escaping sound disappears and confirm that remaining pressure disappears and keep the safety of work.
- 3) Lightly tap the bonnet flange and remove the assembly of the valve disc, stem and bonnet from the body. When the gasket only to be replaced, the gasket can be removed out from the body, at this stage.
- 4) Remove the disc from the stem. Caution shall be so taken as not to cause damages to its seating faces. For re-assembling the valve, the valve disc shall be marked a match mark as shown in Figure 6.1. As it is, valve seat surfaces are coincided as before condition and valve leakage can be prevented.

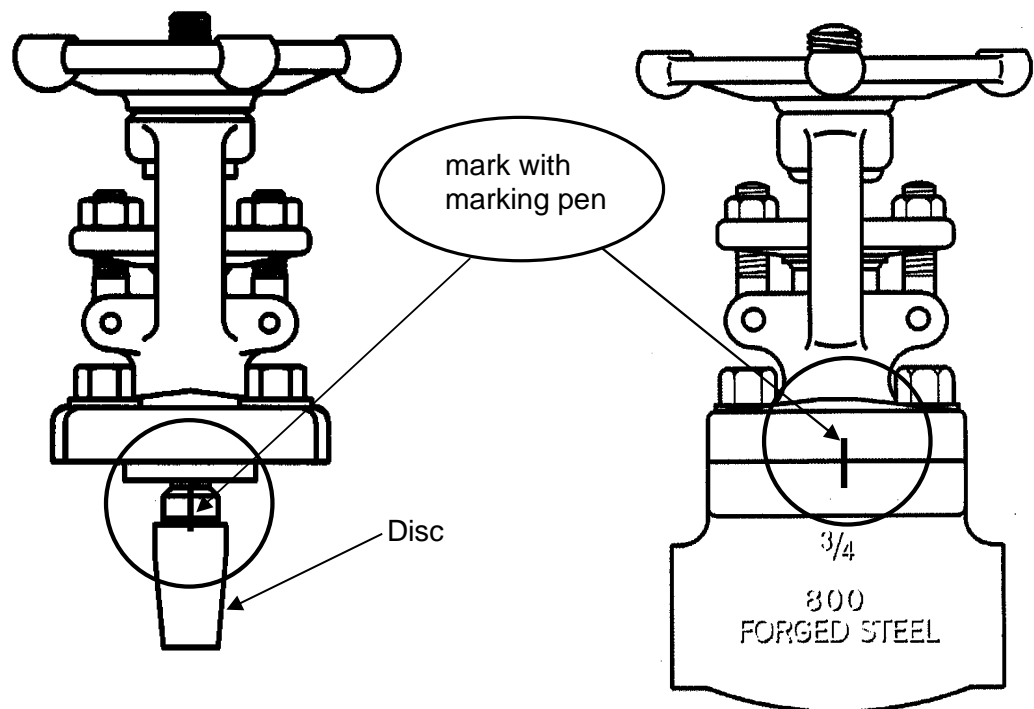



Figure 6.1 Example for Marking Method of Match mark

- 5) Loose both sides of gland bolt nuts and hold the stem at the T-head end and pull out the stem downward by turning hand wheel to the clockwise.
- 6) Remove the gland bolt nuts by turning them to the counter-clockwise and then loosen and pull up the gland flange.

- 7) Remove the hand wheel by pulling it upward while being tapped lightly. At the same time, the sleeve, the sleeve washer, gland flange and gland can be removed.
- 8) Hold the bonnet by a holder (vice and etc.) at the bonnet flange, and remove the lock nut by turning it to the counter-clockwise. In normal, two sleeve washers are used. Caution shall be so taken as not to loose any small component parts.
- 9) Remove the gland packing from the stuffing box. Normally, a new packing rings set shall be used.

■ Assembling Procedure

- Caution to Assembling

 CAUTION
<ul style="list-style-type: none">● Perform the work by person who learned sufficient skill and technical knowledge.● Perform the work with protection guards (protection glasses, gloves for the work, safety shoes).● Use suitable tools properly.● Replace the new gasket and gland packings because they are damaged while disassembling.

■ Before Assembling

- Every part shall be assembled after have been cleaned and checked free from injurious defects or damage. If there is defect or damage in assembled parts, do not use again and replace with new one.
- Keep necessary lighting in the assembling workshop.
- Perform assembling in the workshop where there is less vibration, no dust and no moisture.

■ Assembling

- 1) The assembling procedure shall be in the reverse order of the disassembling order.
- 2) In this case, the gland bolts, bonnet bolts and screw parts shall be coated with grease (Note) in order to prevent them from seizure.
- 3) When insert the gland pickings in the stuffing box, each packing ring shall be inserted successively by tightening up the gland each time. Make sure that there is no overlap of cut of gland pickings, which must be staggered. Apply proper insert force on the gland when inserting.
- 4) For tightening the bonnet bolts, diagonal opposite bolts shall be tightened alternately as shown in Figure 6.2 until the body flange and bonnet flange come into close contact.
- 5) Tightening torque for bonnet bolt is shown in the table 6.1.

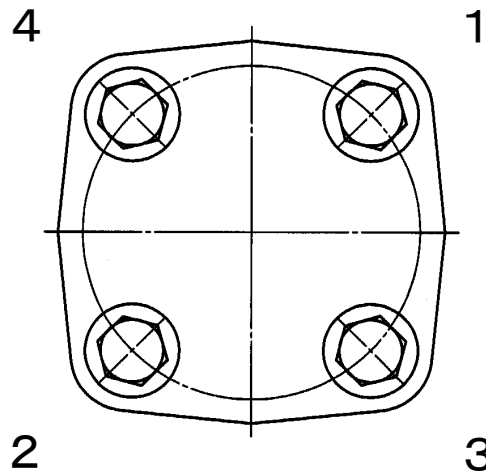
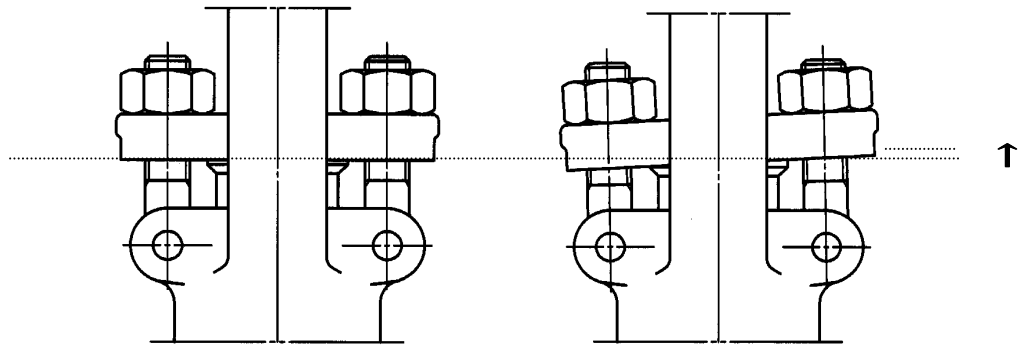

Figure 6.2 Examples for the Sequence of Bonnet Bolts Tightening

- 6) When tightening up the gland bolt nuts, the hand wheel should be turn now and then so to adjust the tightness of the gland packing, as shown in Figure 6.3. Tightening up the gland bolt nuts gradually and uniformly in order to avoid tendency to twist.
- 7) Table 6.2 Tightening torque range (reference data) for gland bolt nut.



Correct

Incorrect

Figure 6.3 Examples for Adjustment (Tightening) of Gland bolt nuts

Section 6

DISASSEMBLING AND ASSEMBLING

2. Globe Valves

■ Disassembling Procedure

Since all valves have been correctly assembled and tested, an easy-going disassembling of valves should be avoided.

● Caution to Disassembling Valve



WARNING

- Disassemble the valve carefully and gradually, after confirming that the pressure in pipeline falls down completely and there is no remaining pressure inside of the valve and pipeline.



CAUTION

- Perform the work by person who learned sufficient skill and technical knowledge.
- Perform the work with protection guards (protection glasses, gloves for the work, safety shoes).
- Use suitable tools properly.

■ Before Disassembling

- Keep necessary lighting in the disassembling workshop.
- Perform disassembling in the workshop where there is no vibration, no dust and no moisture.
- Make the match mark on the body-bonnet joint by marking pen as shown in Figure. 6.1 before loosening the bonnet bolts. When assemble the valve, body and bonnet shall be fitted by match mark.

■ Disassembling

- 1) Turn the hand wheel of the fully closed valve to the left to obtain an intermediate valve opening. Since the body seat rings and disc of the closed globe valve are in close contact, it is difficult to disassemble the valve as it is. Therefore, it is necessary to open such valve to an intermediate position so it makes disassembling easier.
- 2) Remove four bonnet bolts in diagonal line by turning them to counter-clockwise under the condition as it is. If there is remaining pressure inside the valve, there is leakage together with the escaping sound at this moment. Leave the disassembling valve until the escaping sound disappears and confirm that remaining pressure disappears and keep the safety of work.

- 3) Lightly tap the bonnet flange and remove the assembly of the valve disc, stem and bonnet from the body. When the gasket only to be replaced, the gasket can be removed out from the body, at this stage.
- 4) Remove the disc from the stem.
- 5) Hold the bonnet by a holder (vice and etc.) at the bonnet flange.
- 6) Remove the nut and washer.
- 7) Remove the hand wheel.
- 8) Remove the gland bolt nuts and then loosen and pull out the gland flange.
- 9) Under this condition, pull out the stem by turning it to the clock-wise direction.
- 10) At the same time, the gland flange and gland can be removed.
- 11) Remove the gland packing from the stuffing box. Normally, a new packing rings set shall be used.
- 12) Since the sleeve has been screwed into the upper part of the bonnet and spot-welded, these spot welds need to be removed by chisel. Then the sleeve can be removed by turning it to the counter-clockwise direction while being tapped slightly.

■ Assembling Procedure

● Caution to Assembling



CAUTION

- Perform the work by person who learned sufficient skill and technical knowledge.
- Perform the work with protection guards (protection glasses, gloves for the work, safety shoes).
- Use suitable tools properly.
- Replace the new gasket and gland packings because they are damaged while disassembling.

■ Before Assembling

- Every part shall be assembled after have been cleaned and checked free from injurious defects or damage. If there is defect or damage in assembled parts, do not use again and replace with new one.
- Keep necessary lighting in the assembling workshop.
- Perform assembling in the workshop where there is no vibration, no dust and no moisture.

■ Assembling

- 1) The assembling procedure shall be in the reverse order of the disassembling order.
- 2) In this case, the gland bolts, bonnet bolts and screw parts shall be coated with grease (Note) in order to prevent them from seizure.
- 3) When insert the gland pickings in the stuffing box, each packing ring shall be inserted successively by tightening up the gland each time. Make sure that there is no overlap of cut of gland packing, which must be staggered. Apply proper insert force on the gland when inserting.
- 4) For tightening the bonnet bolts, diagonal opposite bolts shall be tightened alternately as shown in Figure 6.2 until the body flange and bonnet flange come into close contact.
- 5) Tightening torque for bonnet bolt is shown in the table 6.1.
- 6) When tightening up the gland bolt nuts, the hand wheel should be turn now and then so to adjust the tightness of the gland packing, as shown in Figure 6.3. Tightening up the gland bolt nuts gradually and uniformly in order to avoid tendency to twist.
- 7) Table 6.2 Tightening torque range (reference data) for gland bolt nut.

Note: Unless otherwise specified, bonnet bolts shall be coated with Molykote 1000 anti-seize lubricant (applied to thread connections), and threads on the valve stem for class 900 and over valves shall be coated with Molkote G-n Paste, manufactured by Dow Corning Toray Co., Ltd

Threads on the valve stem for under class 900 valves shall be coated with NEVER SEEZ (regular grade) manufactured by Bostil Inc. USA.

Import source : Kyokuto Boeki Kaisha, Ltd.

Section 6

DISASSEMBLING AND ASSEMBLING

3. Check Valves

■ Disassembling Procedure

Since all valves have been correctly assembled and tested, an easy-going disassembling of valves should be avoided.

● Caution to Disassembling



WARNING

- Disassemble the valve carefully and gradually, after confirming that the pressure in pipeline falls down completely and there is no remaining pressure inside of the valve and pipeline.



CAUTION

- Perform the work by person who learned sufficient skill and technical knowledge.
- Perform the work with protection guards (protection glasses, gloves for the work, safety shoes).
- Use suitable tools properly.

■ Before Disassembling

- Keep necessary lighting in the disassembling workshop.
- Perform disassembling in the workshop where there is no vibration, no dust and no moisture.
- Make the match mark on the body-bonnet joint by marking pen as shown in Figure 6.1 before loosening the bonnet bolts. When assemble the valve, body and bonnet shall be fitted by match mark.

■ Disassembling

- 1) Remove four bonnet bolts in diagonal line by turning them to counter-clockwise under the condition as it is. If there is remaining pressure inside the valve, there is leakage together with the escaping sound at this moment. Leave the disassembling valve until the escaping sound disappears and confirm that remaining pressure disappears and keep the safety of work.
- 2) Remove the bonnet. At this stage, the gasket can be replaced with a new one.
- 3) Remove the valve disc from the valve body.

■ Assembling Procedure

● Caution to Assembling



CAUTION

- Perform the work by person who learned sufficient skill and technical knowledge.
- Perform the work with protection guards (protection glasses, gloves for the work, safety shoes).
- Use suitable tools properly.
- Replace the new gasket because they are damaged while disassembling.

■ Before Assembling

- Every part shall be assembled after have been cleaned and checked free from injurious defects or damage. If there is defect or damage in assembled parts, do not use again and replace with new one.
- Keep necessary lighting in the assembling workshop.
- Perform assembling in the workshop where there is no vibration, no dust and no moisture.

■ Assembling

- 1) The assembling procedure shall be in the reverse order of the disassembling order.
- 2) For tightening the bonnet bolts, diagonal opposite bolts shall be tightened alternately and uniformly as shown in Figure 6.2 until the body flange and bonnet flange come into close contact.
- 3) Bonnet bolts tightening torque shall be as shown in Table 6.1.

Table 6.1 Tightening torque range (reference data) for bonnet bolt

Class	Shoritsu's Valve Type No.	Unit	Nominal Size (Inch)				
			1/2 "	3/4 "	1 "	1-1/2 "	2 "
Class 800	04	kg f-cm	290~310	290~ 310	580~ 630	840~ 890	1300~1400
		N-m	29~ 31	29~ 31	58~ 63	84~ 89	130~ 140
Class 300	03	kg f-cm	250~350	250~ 350	450~ 550	650~ 750	1600~1700
		N-m	25~ 35	25~ 35	45~ 55	65~ 75	160~ 170
Class 600	F3	kg f-cm	250~350	450~ 550	650~ 750	1000~1100	1600~1700
		N-m	25~ 35	45~0055	65~ 75	100~ 110	160~ 170
Class1500	H3	kg f-cm	840~900	1100~1150	1380~1430	3300~3400	3300~3400
		N-m	84~ 90	110~ 115	138~ 143	330~ 340	330~ 340

Table 6.2 Tightening torque range (reference data) for gland bolt nut

Class	Shoritsu's Valve Type No.	Unit	Nominal Size (Inch)				
			1/2 "	3/4 "	1 "	1-1/2 "	2 "
Class 800	041	kg f-cm	50~ 70	50~ 70	70~ 90	140~160	150~170
		N-m	5~ 7	5~ 7	7~ 9	14~ 16	15~ 17
Class 800	042	kg f-cm	50~ 70	50~ 70	70~ 90	140~160	160~180
		N-m	5~ 7	5~ 7	7~ 9	14~ 16	16~ 18
Class 300	03	kg f-cm	200~220	200~220	230~250	240~260	360~380
		N-m	20~ 22	20~ 22	23~ 25	24~ 26	36~ 38
Class 600	F3	kg f-cm	200~220	230~250	240~260	260~280	360~380
		N-m	20~ 22	23~ 25	24~ 26	26~ 28	36~ 38
Class 1500	H3	kg f-cm	260~280	280~300	280~300	420~440	420~440
		N-m	26~ 28	28~ 30	28~ 30	42~ 44	42~ 44

Section 7 TROUBLESHOOTING GUIDE

■ Caution to Disassembling Valve

 <h2 style="margin: 0; display: inline-block;">CAUTION</h2>
<ul style="list-style-type: none"> ● Perform the work by person who learned sufficient skill and technical knowledge. ● Perform the work with protection guards (protection glasses, gloves for the work, safety shoes). ● Use suitable tools properly. ● The practice of repacking under pressure is not recommended because the backseat of the valve which being used several years cannot prevent the valve leakage.

■ Trouble and Troubleshooting

Trouble	Cause	Troubleshooting
Leakage from the gland	1) Sealing efficiency of gland packings becomes inferior. 2) Lack of the tightening pressure on the gland.	1) Open the valve fully so that the leakage will stop because of back seat. 2) Then, loosen gland bolt nuts, leave the valve as it is for five to ten minutes until the leakage disappear. 3) Retighten the gland bolt nuts in order to further compress the gland packing. 4) If necessary, renew the gland packing. If necessary, add the gland packing.

Trouble	Cause	Troubleshooting
Fluid leakage from the bonnet gasket joint	1) Lack of the tightening pressure on the bonnet	1) The bonnet bolts shall be re-tightened with care so as not to damage the bolts. 2) In case of leakage even after re-tightening of the bonnet bolt nuts, the gasket must be renewed. In this case, stop the fluid flow once.
Seat leakage	1) Foreign materials & scale accumulate and stick to the valve disc.	1) Disassemble the valve and lap the valve, after the pressure in the pipe line falls down completely and confirm that there is no remaining pressure inside the pipe and valve. 2) Washing and cleaning the valve after valve lapping.
Operation is heavy	1) Foreign materials accumulate in the valve stem screw and at the bottom of valve body inside.	1) Open the valve, and remove the accumulated foreign materials by the flow of fluid. 2) Disassemble and clean the valve when operation is still heavy. Refer to “Section 6, Assembling & Disassembling” for the procedure of disassembling.

Section 8

NAME PLATE SPECIFICATION

The name plate indicates manufacturer's name, country of origin, the kind and type of the valve, nominal size, applicable pressure rating at 100° F (38°C), body material and trim material. The position and method of attachment for name plate shall be as follows.

- The position and method of attachment for name plate

Kind of valve	Attached Position	Method for Attachment
Gate valve Globe valve	Upper side of hand wheel	By fitting of hand wheel nut
Check valve	Front side of bonnet flange	By spot-welding, however, for low alloy steel valves, fix by machine screw.

● Example of name plate for exported valve

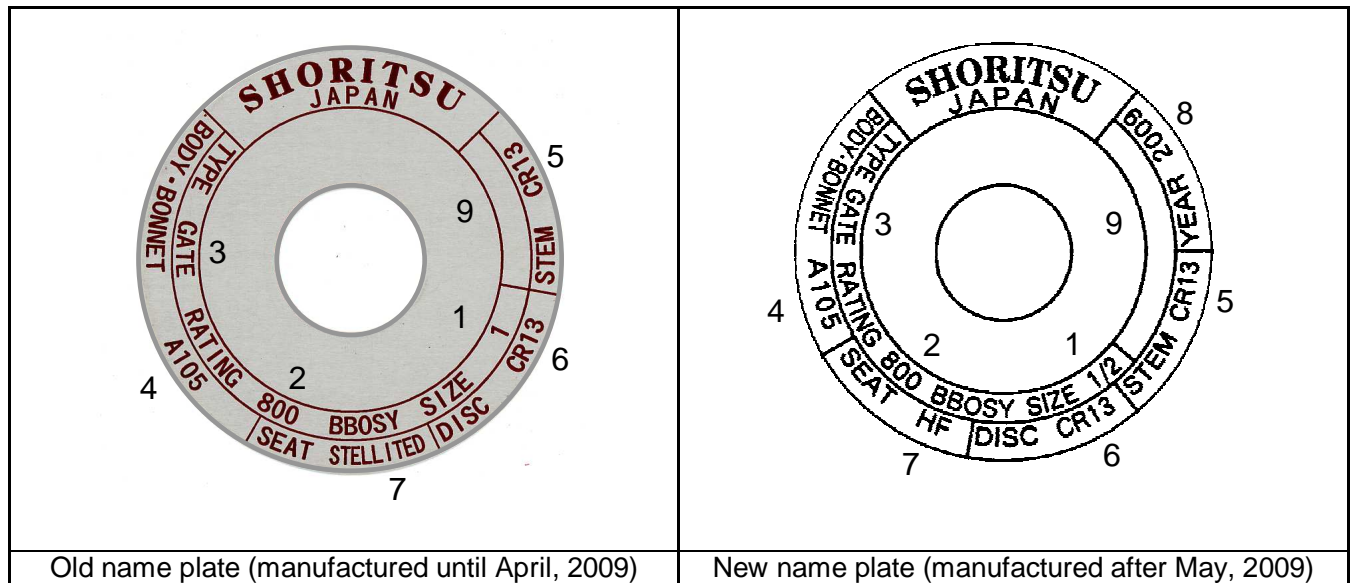

Legend 1~9 of above figure represent as per following table.

No.	Marking item	Meaning of marking	Example for marking (old name plate)	Change existence	Example of marking (new name plate)
—	Material	Material of name plate	Aluminum	Not changed	Aluminum
—	Thickness	Thickness of name plate	0.5 mm	Not changed	0.5 mm
—	Color of material	Color of material for name plate	Gray	→	White
—	Letter	Color of letter	Red	Not changed	Red
1	SIZE	Nominal size of valve (Inch)	1	Not changed	1/2
2	RATING	Rating	800	→	800
3	TYPE	Marking for type in capital letter	GATE	Not changed	GATE
4	BODY BONNET	Body and bonnet material	A105	Not changed	A105
5	STEM	Stem material	13Cr	→	CR13
6	DISC	Disc seat material ■ Stellite on body seat ■ No stellite	(STELLITED) CR13	→ Not changed	(HF) CR13
7	SEAT	Seat material ■ Stellite on body seat ■ No stellite	STELLITED	→	HF
8	YEAR	Year of manufacture (Christian era)	—	Standard specification	2009
9	VALVE NUMBER	Valve number	Not specified	Customer specification	Not specified

Note : In the () of the example for marking is as reference.

● Example of name plate for exported check valve

<table border="1"> <tr><td colspan="4">SHORITSU JAPAN</td></tr> <tr><td>TYPE</td><td>CHECK</td><td>DISC</td><td>CR13</td></tr> <tr><td>RATING</td><td>800</td><td>SEAT</td><td>STELLITED</td></tr> <tr><td>SIZE</td><td>1</td><td></td><td></td></tr> <tr><td>BONNET-BODY</td><td>A105</td><td></td><td></td></tr> </table>	SHORITSU JAPAN				TYPE	CHECK	DISC	CR13	RATING	800	SEAT	STELLITED	SIZE	1			BONNET-BODY	A105			<table border="1"> <tr><td colspan="4">SHORITSU JAPAN</td></tr> <tr><td>TYPE</td><td>CHECK</td><td>DISC</td><td>CR13</td></tr> <tr><td>RATING</td><td>800</td><td>SEAT</td><td>HF</td></tr> <tr><td>SIZE</td><td>1 1/2</td><td>YEAR</td><td>2009</td></tr> <tr><td>BODY-BONNET</td><td>A105</td><td></td><td></td></tr> </table>	SHORITSU JAPAN				TYPE	CHECK	DISC	CR13	RATING	800	SEAT	HF	SIZE	1 1/2	YEAR	2009	BODY-BONNET	A105		
SHORITSU JAPAN																																									
TYPE	CHECK	DISC	CR13																																						
RATING	800	SEAT	STELLITED																																						
SIZE	1																																								
BONNET-BODY	A105																																								
SHORITSU JAPAN																																									
TYPE	CHECK	DISC	CR13																																						
RATING	800	SEAT	HF																																						
SIZE	1 1/2	YEAR	2009																																						
BODY-BONNET	A105																																								
Old name plate (manufactured until April, 2009)	New name plate (manufactured after May, 2009)																																								

Legend 1~9 of above figure represent as per following table.

No.	Marking item	Meaning of marking	Example for Marking (old name plate)	Change existence	Example of Marking (new name plate)
—	Material	Material of name plate	Stainless steel	Not changed	Stainless steel
—	Thickness	Thickness of name plate	0.5 mm	Not changed	0.5 mm
—	Color of material	Color of material for name plate	Ground (burnishing)	→	Ground (burnishing)
—	Letter line	Color of letter	Red	Not changed	Red
1	SIZE	Nominal size of valve (Inch)	1	Not changed	1 1/2
2	RATING	Rating	800	→	800
3	TYPE	Marking for type in capital letter	CHECK	Not changed	CHECK
4	BODY BONNET	Body and bonnet material	A105	Not changed	A105
6	DISC	Disc seat material ■ Stellite on body seat ■ No stellite	(STELLITED) CR13	→ Not changed	(HF) CR13
7	SEAT	Seat material ■ Stellite on body seat ■ No stellite	STELLITED —	→	HF —
8	YEAR	Year of manufacture (Christian era)	—	Standard specification	2009
9	VALVE NUMBER	Valve number	Not specified	Customer specification	Not specified

Note : In the () of the example for marking is as reference



Section 9 GUARANTEE



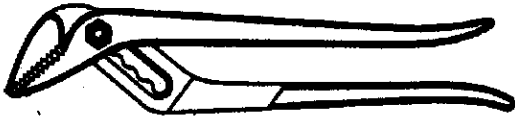
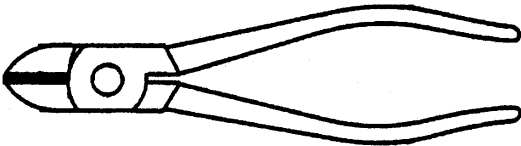

- All valves have been correctly assembled and tested. Please contact to our company if and there are unclear points, troubles, repairs and your request.
- Guarantee period of the valve shall be in accordance with purchase order and an agreement between the purchaser and the manufacturer.
- Consult to our company if there are specification changes in accordance with customer's specification, new design, and new product, and so on except for our product specification.
- Please inform the following information when the valve is required to repair and in trouble.
 1. Company name, address, telephone number, post and person in charge
 2. The address of the establishment place, telephone number, post and person in charge
 3. Product name (product type, kind of valve, nominal diameter and so on)
 4. Purchased date and established date
 5. The conditions of trouble and repair (as concretely as possible)
 6. The conditions of applications, the environment (kind of the fluid, pressure, temperature and frequency of application)
 7. The deadline or expected date for valves repair

Section 10 NECESSARY TOOLS

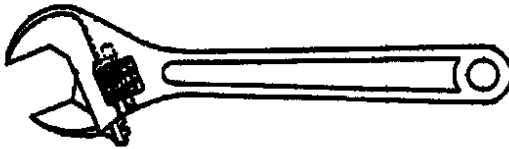
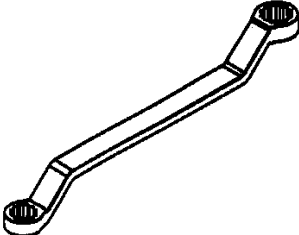
Necessary tools to be used when disassembling, assembling and repairing are as shown in the Table.

Table. Necessary tools when disassembling, assembling and repair

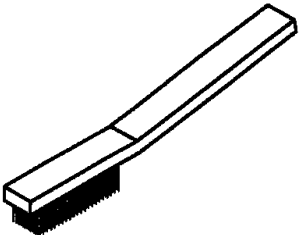
Tool Name	Typical Tool	Use
Water pump Pliers		Use for tightening and loosening the bolt.
Nipper		Use for cutting the gasket when it is expanded.
Pincers		Use for dismantling the gasket from the valve bonnet.
Adjustable Spanner		Use for tightening and loosening of handwheel nut.
Offset Wrench		Use for tightening and loosening of bolts and nuts.

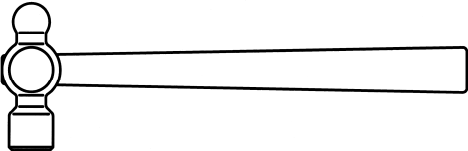
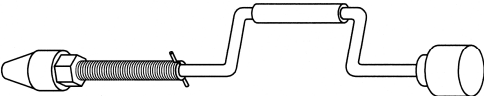
Tool Name	Typical Tool	Use
Handwheel Key		Use for turning the handwheel for additional force.
Extractors for gland packing		Use for extracting of gland packing.
Wire Brush		Use for removal of dust, rust, foreign materials and so on.
Pin Set		Use it as an auxiliary tool when cleaning the corner of valve body and the neighborhood of the hole for the valve disc.
Hammer		Use for installation and dismantling of the handwheel.
Tool for valve lapping		the tool is used for valve seat lapping by rotating it which the water-proof abrasive paper puts on its surface end with double-stick tape.

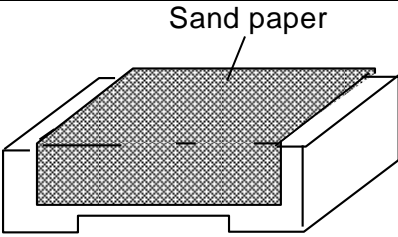
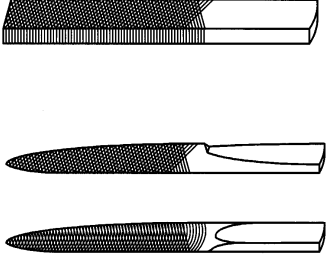
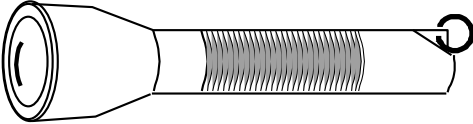
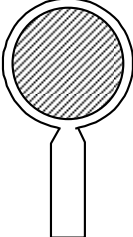
Tool Name	Typical Tool	Use
Abrasive plate for Gate valve		Use for removal of flaw on the surface of valve disc by setting the abrasive paper on the abrasive plate.
Files		Use for removal of burrs.
Portable flashlight		Use it for the confirmation of the existence of the seat damage and, the scale in the corner.
Handy Mirror		Use it when the point can't be confirmed directly with the naked eyes, opposite and back sides of the view, and so on.

E199801-12 FORGED STEEL VALVE USER GUIDE (BB-OS&Y TYPE)

Published	Aug. 1998	
First edition	Dec. 1998	
Second edition	Mar. 1999	
Third edition	Jan. 2001	
Fourth edition	Jul. 2001	
Fifth edition	Feb. 2002	
Sixth edition	Mar. 2002	
Seventh edition	Sep. 2005	
Eighth edition	Jun. 2008	
Ninth edition	Oct. 2008	Change of JAB (The Japan Accreditation Board for Conformity Assessment) recognized symbol and KHK (Kouatsu – Gas Hoan Kyoukai, The High Pressure Gas Safety Institute of Japan) registration logo
Tenth edition	Jul. 2009	Change of nameplate specification
11th edition	Jan.2011	
12th edition	Mar 2012	The grease is changed.

Published by Quality Control Section, Quality Control Department
Shoritsu Seisakusho Co., Ltd. Japan

- The contents of this forged steel valve user guide will be changed without any notice in the future.
- Prohibit the reproduction and the photocopying of any part or the whole of this forged steel valve user guide without prior permission of Shoritsu Seisakusho Co., Ltd.



KHK ISO CENTER, QUALITY SYSTEM CERTIFICATE (ISO 9001)

PRODUCT/SERVICE RANGE : DESIGN AND MANUFACTURE OF FORGED STEEL VALVE

- Please contact the following our Sales Department if there are unclear and noticeable points.
- Keep this valve user guide in the place where handling person can use immediately.

SHORITSU SEISAKUSHO CO., LTD.
Head Office and Sales Department

7-21, Matsushima 2-Chome, Edogawa-Ku, Tokyo 132-0031, Japan

Tel. 81-3-3654-9211, Fax. : 81-3-3651-5688

E-mail: shoritsu@sfv.co.jp

Home Page Address: <http://www.sfv.co.jp/>