

B.S. 3293 FLANGES

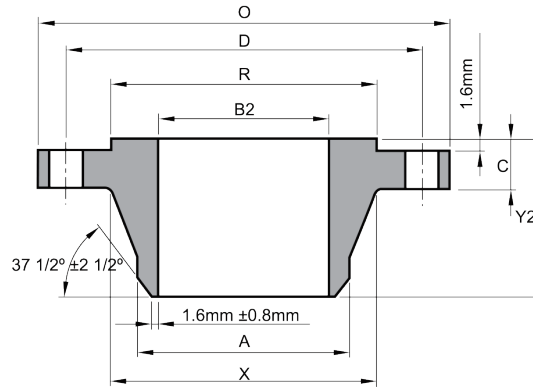

**UNGGUL
PRAKARSA
PRISMA**

CLASS 150 FLANGES



WELDING NECK

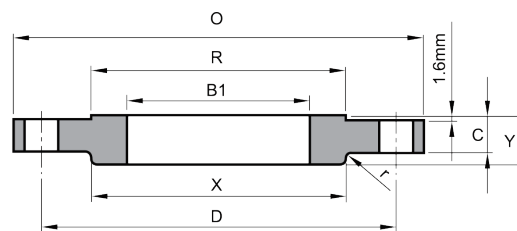

SLIP-ON

Unit : mm

Nominal Pipe Size	O.D. of Flange	Thickness of Flange Min	Outside Diameter of Large End of Hub	Outside Diameter of Small End of Hub	Length Through Hub		Fillet Radius	Flange Bore		Diameter of Bolt Circle	Raised Face	Drilling			Length of Stud - Bolts	Length of Headed Bolts
					Slip-on	Welding Neck		Slip-on	Welding Neck			Number of Bolt Holes	Diameter of Bolts	Diameter of Bolt Holes		
26	870.0	50.8	724.0	660.4	85.5	127.0	6.4	666.8		806.5	743.0	24	32	35.0	171.5	146.0
28	927.0	52.4	781.0	711.2	87.5	128.5	6.4	717.6		863.6	793.8	28	32	35.0	178.0	152.5
30	984.5	54.0	832.0	762.0	89.0	130.0	6.4	768.4		914.4	857.3	28	32	35.0	178.0	152.5
32	1060.5	57.2	889.0	812.8	92.0	133.5	7.9	819.2		977.9	908.1	28	38	41.5	197.0	165.0
34	1111.0	58.7	940.0	863.6	93.5	135.0	7.9	870.0		1028.7	958.9	32	38	41.5	203.0	171.5
36	1168.5	60.3	997.0	914.4	95.5	136.5	7.9	920.8		1085.9	1022.4	32	38	41.5	203.0	171.5
38	1238.0	60.3	1060.5	965.2	95.5	136.5	9.5	971.6		1149.4	1073.2	32	38	41.5	203.0	171.5
40	1289.0	63.5	1111.0	1016.0	98.5	139.5	9.5	1022.4		1200.2	1124.0	36	38	41.5	209.5	178.0
42	1346.0	66.7	1168.5	1066.8	101.5	143.0	9.5	1073.2		1257.3	1193.8	36	38	41.5	216.0	184.0
44	1403.5	66.7	1219.0	1117.6	101.5	143.0	11.1	1123.9		1314.5	1244.6	40	38	41.5	216.0	184.0
46	1454.0	68.3	1270.0	1168.4	103.0	144.5	11.1	1174.7		1365.3	1295.4	40	38	41.5	222.5	190.5
48	1511.5	69.9	1327.0	1219.2	105.0	146.0	11.1	1225.5		1422.4	1358.9	44	38	41.5	222.5	190.5

To be specified by Purchaser.

CLASS 300 FLANGES

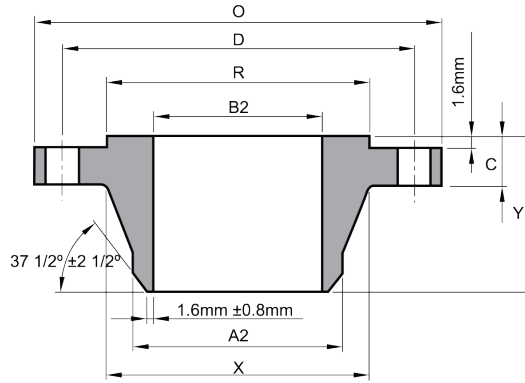

WELDING NECK

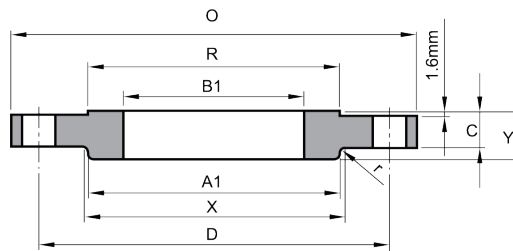

SLIP-ON

Unit : mm

Nominal Pipe Size	O.D. of Flange O	Thickness of Flange Min C	Outside Diameter of Large End of Hub X	Outside Diameter Small end of Hub		Length Thr. Hub Slip-on and Welding Neck Y	Fillet Radius r	Flange Bore		Drilling	
				Slip-on	Welding Neck			Slip-on	Welding Neck	Diameter of Bolt Circle D	Number of Bolts
				A1	A2	B1					
26	971.5	79.4	720.5	687.4	666.8	184.0	9.5	666.8	To Be Specified By The Purchaser	876.3	28
28	1035.0	85.7	774.5	739.8	717.6	197.0	11.1	717.6		939.8	28
30	1092.0	92.1	827.0	792.2	768.4	209.5	11.1	768.4		997.0	28
32	1149.5	98.4	881.0	844.6	819.2	222.0	11.1	819.2		1054.1	28
34	1206.5	101.6	936.5	896.9	871.5	232.0	12.7	870.0		1104.9	28
36	1270.0	104.8	990.5	949.3	922.3	241.5	12.7	920.8		1168.4	32

CLASS 300 FLANGES

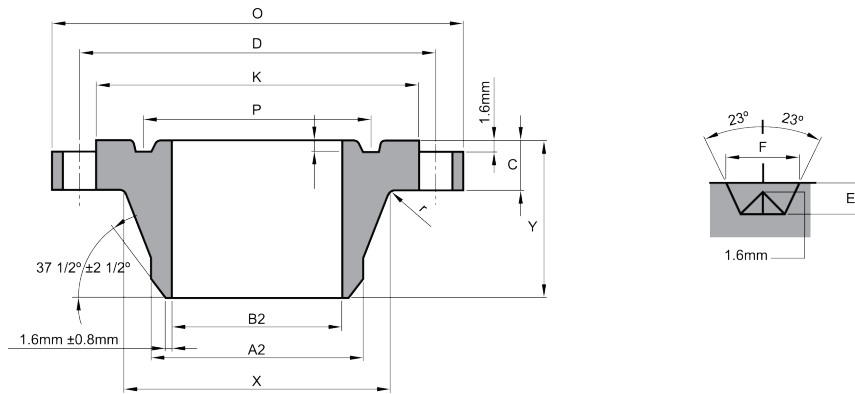

**WELDING NECK
RING JOINT**

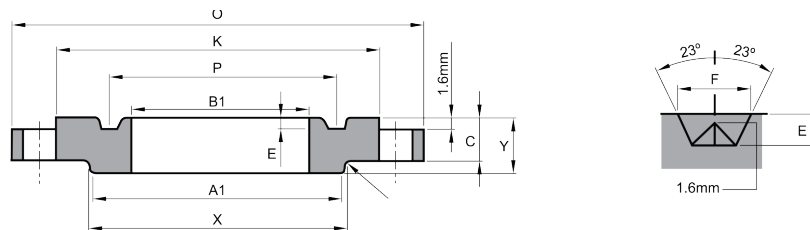

**SLIP-ON
RING JOINT**

Unit : mm

Nominal Pipe Size	Drilling		Facing Dimensions						Length of Stud Bolts		Length of headed bolts	
	Diameter of Bolts	Diameter of Bolt Holes	Raised Face	Ring - Joint			Diam. of Raised Portion	Ring Number	Raised Face	Ring Joint	Raised Face	Ring Joint
			Outside Diam.	Pitch Diam.	Groove Width	Depth of groove E.						
26	41.5	44.5	749.3	749.3	19.9	12.7	809.6	R93	247.5	279.5	216.0	241.5
28	41.5	44.5	800.1	800.1	19.9	12.7	860.6	R94	260.5	292.0	228.5	254.0
30	44.5	47.5	857.3	857.3	19.9	12.7	917.6	R95	279.5	311.0	241.5	267.0
32	47.5	51.0	914.4	914.4	23.2	14.3	984.3	R96	298.5	330.0	260.5	286.0
34	47.5	51.0	965.2	965.2	23.2	14.3	1035.1	R97	305.0	336.5	267.0	292.0
36	51.0	54.0	1022.4	1022.4	23.2	14.3	1092.2	R98	317.5	349.5	273.0	305.0

CLASS 400 FLANGES

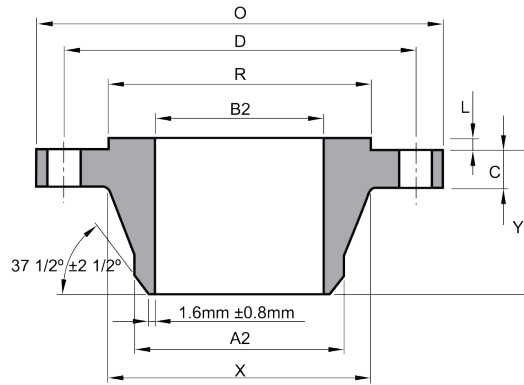

WELDING NECK

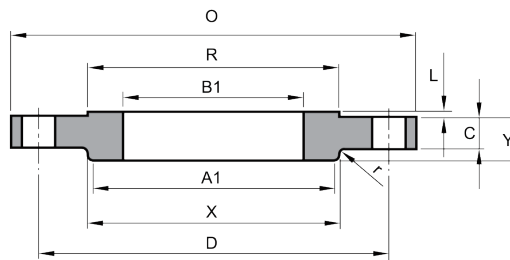

SLIP-ON

Unit : mm

Nominal Pipe Size	O.D. of Flange	Thickness of Flange Min	Outside Diameter of Large End of Hub	Outside Diameter Small end of Hub		Length Thr. Hub	Fillet Radius	Flange Bore		Drilling	
				Slip-on	Welding Neck			Slip-on	Welding Neck	Diameter of Bolt Circle	Number of Bolts
				A1	A2						
26	971.5	88.9	727.0	693.7	668.3	193.5	11.1	666.8	To Be Specified By The Purchaser	876.3	28
28	1035.0	95.3	782.5	746.1	719.1	206.5	12.7	717.6		939.8	28
30	1092.0	101.6	836.5	800.1	769.9	219.0	12.7	768.4		997.0	28
32	1149.5	108.0	889.0	852.5	822.3	232.0	12.7	819.2		1054.1	28
34	1206.5	111.1	944.5	905.1	873.1	241.5	14.3	870.0		1104.9	28
36	1270.0	114.3	1000.0	958.9	925.5	251.0	14.3	920.8		1168.4	32

CLASS 400 FLANGES

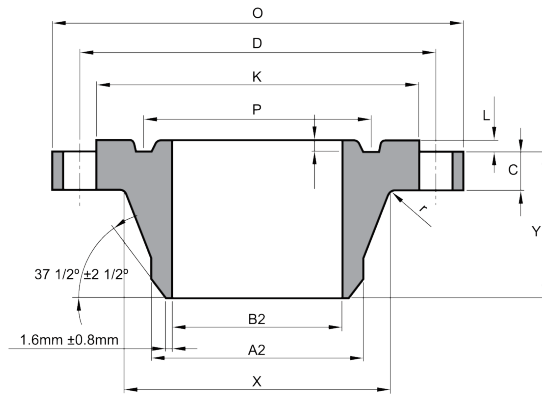

**WELDING NECK
RING JOINT**

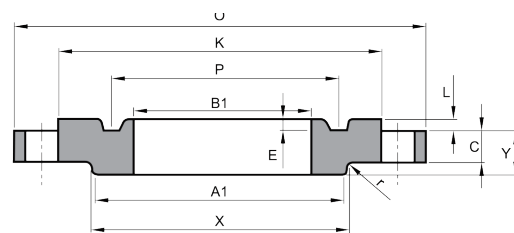
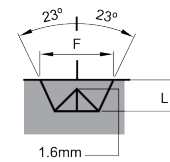

**SLIP-ON
RING JOINT**

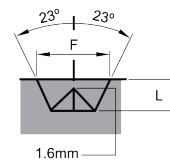

Unit : mm

Nominal Pipe Size	Drilling		Facing Dimensions						Length of Stud Bolts	
	Diameter of Bolts	Diameter of Bolt Holes	Raised Face	Ring - Joint				Ring Number	Raised Face	Ring Joint
			Outside Diam.	Pitch Diam.	Groove Width	Depth of groove E. Height of facing L.	Diam. of Raised Portion			
R	P	F	L	K						
26	44.5	47.5	749.3	749.3	19.9	12.7	809.6	R93	285.5	317.5
28	47.5	51.0	800.1	800.1	19.9	12.7	860.4	R94	305.5	336.5
30	51.0	54.0	857.3	857.3	19.9	12.7	917.6	R95	324.0	355.5
32	51.0	54.0	914.4	914.4	23.1	14.3	984.3	R96	336.5	374.5
34	51.0	54.0	965.2	965.2	23.1	14.3	1035.1	R97	343.0	381.0
36	51.0	54.0	1022.4	1022.4	23.1	14.3	1092.2	R98	349.5	387.5

CLASS 600 FLANGES

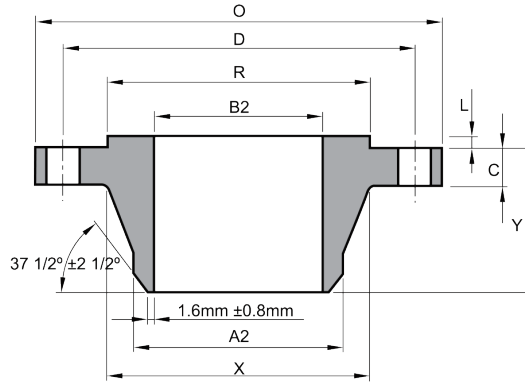

WELDING NECK

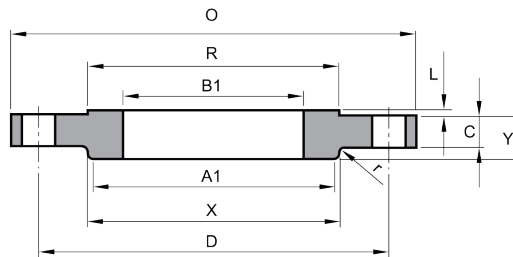

SLIP-ON

Unit : mm

Nominal Pipe Size	O.D. of Flange O	Thickness of Flange Min C	Outside Diameter of Large End of Hub X	Outside Diameter Small end of Hub		Length Thr. Hub Slip-on and Welding Neck Y	Fillet Radius r	Flange Bore		Drilling	
				Slip-on A1	Welding Neck A2			Slip-on B1	Welding Neck B2	Diameter of Bolt Circle D	Number of Bolts
26	1016.0	108.0	747.5	706.4	671.5	222.5	14.3	666.8	To Be Specified By The Purchaser	914.4	28
28	1073.0	111.1	803.5	760.4	723.9	235.0	15.9	717.6		965.2	28
30	1130.5	114.3	862.0	814.4	774.7	247.5	17.5	768.4		1022.4	28
32	1194.0	117.5	917.5	868.4	825.5	260.5	17.5	819.2		1079.5	28
34	1244.5	120.7	973.0	922.3	877.9	270.0	19.1	870.0		1130.3	28
36	1314.5	123.8	1032.0	976.3	928.7	282.5	19.1	920.8		1193.8	28

CLASS 600 FLANGES

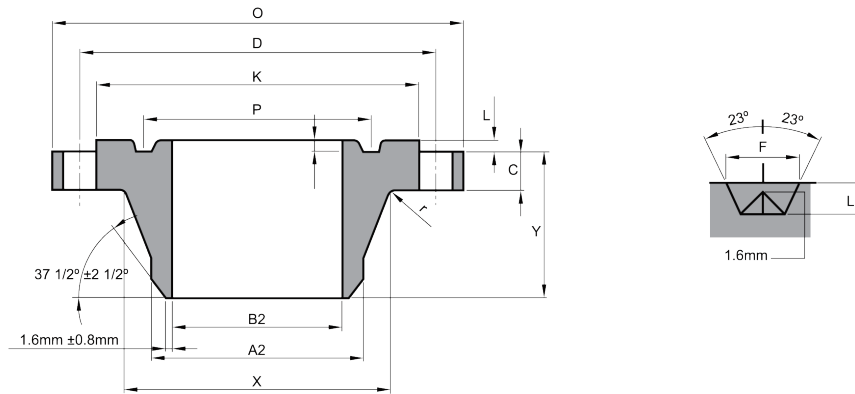

**WELDING NECK
RING JOINT**

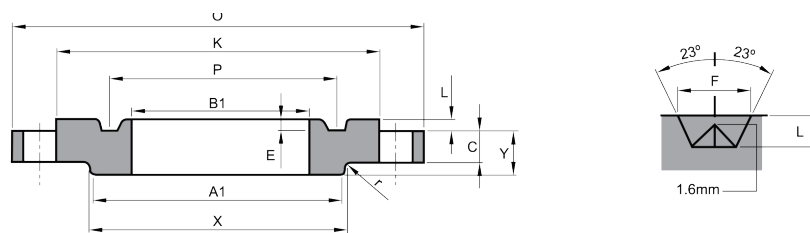

**SLIP-ON
RING JOINT**

Unit : mm

Nominal Pipe Size	Drilling		Facing Dimensions						Length of Stud Bolts	
	Diameter of Bolts	Diameter of Bolt Holes	Raised Face	Ring - Joint				Ring Number	Raised Face	Ring Joint
			Outside Diam.	Pitch Diam.	Groove Width	Depth of groove E. Height of facing L.	Diam. of Raised Portion			
			R	P	F	L	K			
26	47.5	51.0	749.3	749.3	19.9	12.7	809.6	R93	330.0	362.0
28	51.0	54.0	800.1	800.1	19.9	12.7	860.4	R94	343.0	374.5
30	51.0	54.0	857.3	857.3	19.9	12.7	917.6	R95	349.0	381.0
32	57.0	60.5	914.4	914.4	23.1	14.3	984.3	R96	368.5	406.5
34	57.0	60.5	965.2	965.2	23.1	14.3	1035.1	R97	374.5	413.0
36	63.5	66.5	1022.4	1022.4	23.	14.3	1092.2	R98	393.5	432.0