

# **ANSI\_ASME B16.47 A**

**(MSS SP-44)**



**UNGGUL  
PRAKARSA  
PRISMA**

Komplek Ruko Intercon Plaza Blok D No. 9, Jl. Meruya Ilir raya , Srengeseng , Jakarta Barat 11630  
Phone : 6221 5890 1302 Email : [unggulpp@upp.co.id](mailto:unggulpp@upp.co.id) Web : [www.unggulpp.com](http://www.unggulpp.com)

# CLASS 150 FLANGES

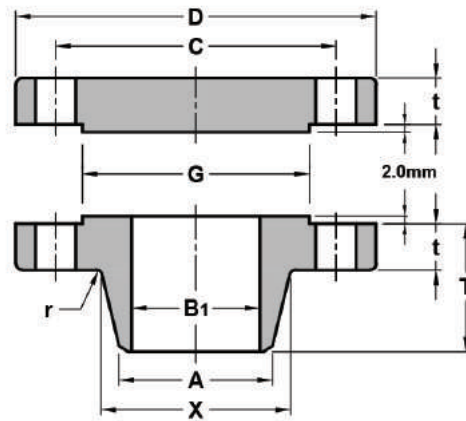

Unit : mm

Nominal Pipe Size	O.D of Flange	Thickness		Diam. Of Bore	Length Through Hub	O.D of Raised Face	Diam. of Hub at Bevel	Diam. Of Hub	Drilling			Approximate Weight(Kg)		
		Welding Neck	Blind						Bolt Circle Diam.	Number of Holes	Diam. Of Holes	Radius of Fillet	Welding Neck	Blind
		t	t											
26	870	66.7	66.7	To be Specified by Purchaser	119	749	660.4	676	806.4	24	34.9	10	149.3	306.2
28	925	69.9	69.9		124	800	711.2	727	863.6	28	34.9	11	169.1	361.9
30	985	73.1	73.1		135	857	762	781	914.4	28	34.9	11	199.8	431
32	1060	79.4	79.4		143	914	812.8	832	977.9	28	41.3	11	247.9	537
34	1110	81	81		148	965	863.6	883	1028.7	32	41.3	13	264.8	599.5
36	1170	88.9	88.9		156	1022	914.4	933	1085.8	32	41.3	13	316.4	733.3
38	1240	85.8	85.8		156	1073	965.2	991	1149.4	32	41.3	13	352.4	798.7
40	1290	88.9	88.9		162	1124	1016	1041	1200.2	36	41.3	13	378.6	894
42	1345	95.3	95.3		170	1194	1066.8	1092	1257.3	36	41.3	13	431	1044.4
44	1405	100.1	100.1		176	1245	1117.6	1143	1314.4	40	41.3	13	484	1195.3
46	1455	101.6	101.6		184	1295	1168.4	1197	1365.2	40	41.3	13	516.5	1304.1
48	1510	106.4	106.4		191	1359	1219.2	1248	1422.4	44	41.3	13	567.2	1469.3
50	1570	109.6	109.6		202	1410	1270	1302	1479.6	44	47.6	13	616.7	1622.7
52	1625	114.3	114.3		208	1461	1320.8	1353	1536.7	44	47.6	13	676.9	1816.9
54	1685	119.1	119.1		214	1511	1371.6	1403	1593.8	44	47.6	13	752.5	2039.8
56	1745	122.3	122.3		227	1575	1422.4	1457	1651	48	47.6	13	827.2	2244.6
58	1805	127	127		233	1626	1473.2	1508	1708.2	48	47.6	13	913.6	2498.5
60	1855	130.2	130.2		238	1676	1524	1559	1759	52	47.6	13	958	2700.2

# CLASS 300 FLANGES

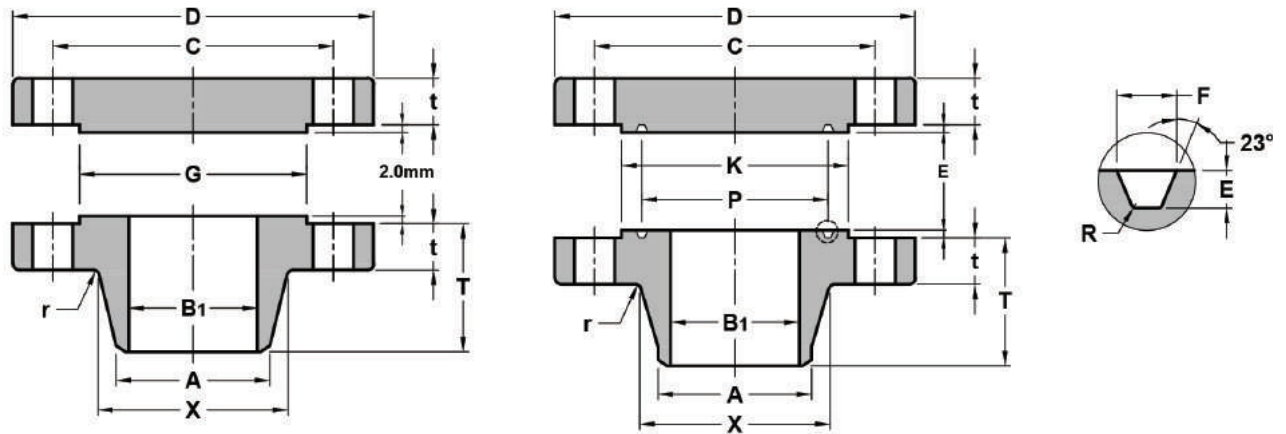

Unit : mm

Nominal Pipe Size	Thickness		Diam. Of Bore	Length Through Hub	O.D of Raised Face	Diam. of Hub at Bevel	Diam. Of Hub	Drilling			Radius of Fillet	Ring Type Joint					Approximate Weight(Kg)			
	O.D of Flange	Welding Neck						Blind	Bolt Circle Diam.	Number of Holes		Diam. Of Holes	Pitch Diam.	Groove Width	Groove Depth	Radius at Bottom	Diam. of Raised Face	Groove Number	Welding Neck	Blind
	D	t						t												
26	970	77.8	82.6	To be Specified by Purchaser	183	749	660.4	721	876.3	28	44.5	10	749.3	19.8	12.7	1.5	810	R93	281.3	457.8
28	1035	84.2	88.9		195	800	711.2	775	939.8	28	44.5	11	800.1	19.8	12.7	1.5	861	R94	341.4	564.6
30	1090	90.5	93.7		208	857	762	827	997	28	47.6	11	857.3	19.8	12.7	1.5	917	R95	391.6	658.8
32	1150	96.9	98.5		221	914	812.8	881	1054.1	28	50.8	11	914.4	23	14.3	1.5	984	R96	453.9	769.6
34	1205	100.1	103.2		230	965	863.6	937	1104.9	28	50.8	13	965.2	23	14.3	1.5	1035	R97	507.6	889.4
36	1270	103.2	109.6		240	1022	914.4	991	1168.4	32	54	13	1022.4	23	14.3	1.5	1092	R98	564.5	1037.6
38	1170	106.4	106.4		179	1029	965.2	994	1092.2	32	41.3	13							319.2	875.2
40	1240	112.8	112.8		192	1086	1016	1048	1155.7	32	44.5	13							386.2	1039.8
42	1290	117.5	117.5		198	1137	1066.8	1099	1206.5	32	44.5	13							420.3	1175.6
44	1355	122.3	122.3		205	1194	1117.6	1149	1263.6	32	47.6	13							479.8	1347.3
46	1415	127	127		214	1245	1168.4	1203	1320.8	28	50.8	13							544.6	1530.3
48	1465	131.8	131.8		222	1302	1219.2	1254	1371.6	32	50.8	13							580.1	1697.8
50	1530	138.2	138.2		230	1359	1270	1305	1428.8	32	54	13							660.4	1937.8
52	1580	142.9	142.9		237	1410	1320.8	1356	1479.6	32	54	13							708.4	2141.7
54	1660	150.9	150.9		251	1467	1371.6	1410	1549.4	28	60.3	13							862.5	2495.5
56	1710	152.4	152.4		259	1518	1422.4	1464	1600.2	28	60.3	13							908.8	2680.2
58	1760	157.2	157.2		265	1575	1473.2	1514	1651	32	60.3	13							952.2	2920
60	1810	162	162		271	1626	1524	1565	1701.8	32	60.3	13							1011.7	3095

# CLASS 600 FLANGES

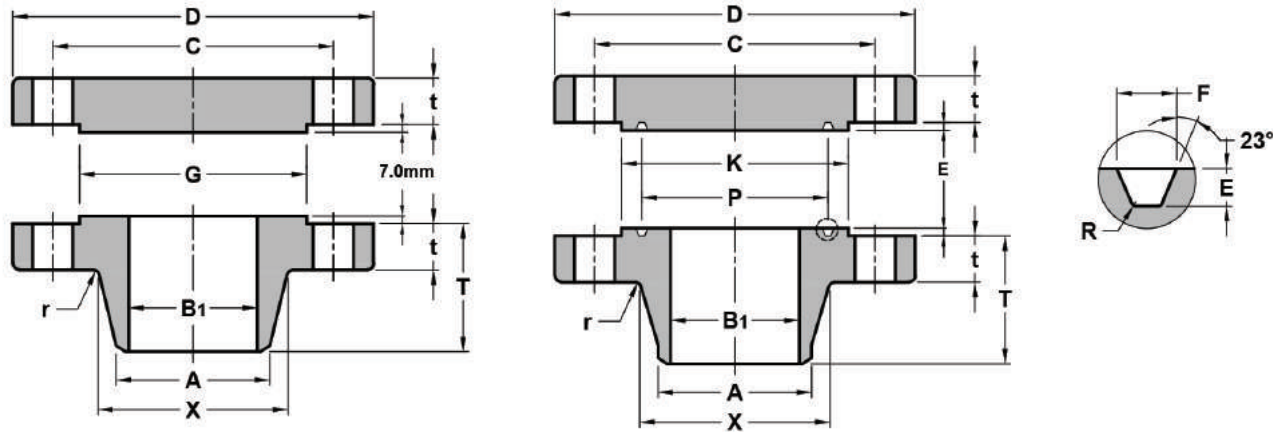

Unit : mm

Nominal Pipe Size	O.D of Flange	Thickness		Diam. Of Bore	Length Through Hub	O.D of Raised Face	Diam. of Hub at Bevel	Diam. Of Hub	Drilling			Radius of Fillet	Ring Type Joint					Approximate Weight(Kg)		
		Welding Neck	Blind						Bolt Circle Diam.	Number of Holes	Diam. Of Holes		Pitch Diam.	Groove Width	Groove Depth	Radius at Bottom	Diam. of Raised Face	Groove Number	Welding Neck	Blind
		t	t																	
26	1015	108	125.5	To be Specified by Purchaser	222	749	660.4	748	914.4	28	50.8	13	749.3	19.8	12.7	1.5	810	R93	441.8	765.4
28	1075	111.2	131.8		235	800	711.2	803	965.2	28	54	13	800.1	19.8	12.7	1.5	861	R94	500.2	900.3
30	1130	114.3	139.7		248	857	762	862	1022.4	28	54	13	857.3	19.8	12.7	1.5	917	R95	565.2	1061.2
32	1195	117.5	147.7		260	914	812.8	918	1079.5	28	60.3	13	914.4	23	14.3	1.5	984	R96	635	1243.7
34	1245	120.7	154		270	965	863.6	973	1130.3	28	60.3	14	965.2	23	14.3	1.5	1035	R97	695.2	1415.2
36	1315	123.9	162		283	1022	914.4	1032	1193.8	28	66.7	14	1022.4	23	14.3	1.5	1092	R98	788	1647.8
38	1270	152.4	155		254	1054	965.2	1022	1162	28	60.3	14							665.1	1492
40	1320	158.8	162		264	1111	1016	1073	1212.8	32	60.3	14							713.5	1677.3
42	1405	168.3	171.5		279	1168	1066.8	1127	1282.7	28	66.7	14							887	2014.4
44	1455	173.1	177.8		289	1226	1117.6	1181	1333.5	32	66.7	14							939.4	2229.5
46	1510	179.4	185.8		300	1276	1168.4	1235	1390.6	32	66.7	14							1036	2519.1
48	1595	189	195.3		316	1334	1219.2	1289	1460.5	32	73	14							1236.2	2934.7
50	1670	196.9	203.2		329	1384	1270	1343	1524	28	79.4	14							1435.7	3355.5
52	1720	203.2	209.6		337	1435	1320.8	1394	1574.8	32	79.4	14							1503.8	3651.2
54	1780	209.6	217.5		349	1492	1371.6	1448	1632	32	79.4	14							1660.7	4074.3
56	1855	217.5	225.5		362	1543	1422.4	1502	1695.4	32	85.7	16							1867.2	4560
58	1905	222.3	231.8		370	1600	1473.2	1553	1746.2	32	85.7	16							1975.4	4961
60	1995	233.4	242.9		389	1657	1524	1610	1822.4	28	92.1	17							2377.1	5723.2

# CLASS 900 FLANGES

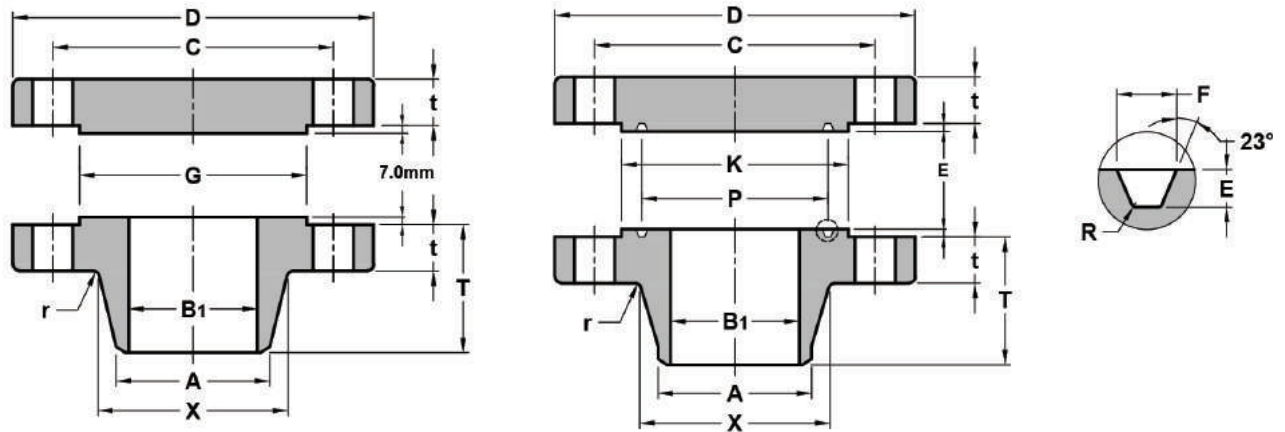

Unit : mm

Nominal Pipe Size	O.D of Flange	Thickness		Diam. Of Bore	Length Through Hub	O.D of Raised Face	Diam. of Hub at Bevel	Diam. Of Hub	Drilling			Radius of Fillet	Ring Type Joint					Approximate Weight(Kg)		
		Welding Neck	Blind						Bolt Circle Diam.	Number of Holes	Diam. Of Holes		Pitch Diam.	Groove Width	Groove Depth	Radius at Bottom	Diam. of Raised Face	Groove Number	Welding Neck	Blind
		t	t																	
26	1085	139.7	160.4	To be Specified by Purchaser	286	749	660.4	775	952.5	20	73	11	749.3	30.2	17.5	2.3	832	R100	795.4	1076.1
28	1170	142.9	171.5		298	800	711.2	832	1022.4	20	79.4	13	800.1	33.3	17.5	2.3	889	R101	934.8	1341.7
30	1230	149.3	182.6		311	857	762	889	1085.8	20	79.4	13	857.3	33.3	17.5	2.3	946	R102	1066.8	1593
32	1315	158.8	193.7		330	914	812.8	946	1155.7	20	85.7	13	914.4	33.3	17.5	2.3	1003	R103	1275.8	1925.7
34	1395	165.1	204.8		349	965	863.6	1006	1225.6	20	92.1	14	965.2	36.5	20.6	2.3	1067	R104	1480.2	2283.2
36	1460	171.5	214.4		362	1022	914.4	1064	1289	20	92.1	14	1022.4	36.5	20.6	2.3	1124	R105	1672.6	2638.5
38	1460	190.5	215.9		352	1099	965.2	1073	1289	20	92.1	19							1642.2	2663.7
40	1510	196.9	223.9		364	1162	1016	1127	1339.8	24	92.1	21							1742.7	2924.8
42	1560	206.4	231.8		371	1213	1066.8	1176	1390.6	24	92.1	21							1891.6	3250.5
44	1650	214.4	242.9		391	1270	1117.6	1235	1463.7	24	98.4	22							2207.8	3798.7
46	1735	225.5	255.6		411	1334	1168.4	1292	1536.7	24	104.8	22							2553.5	4405.1
48	1785	233.4	263.6		419	1384	1219.2	1343	1587.5	24	104.8	24							2736.5	4832.5