



**UNGGUL  
PRAKARSA  
PRISMA**

Komplek Ruko Intercon Plaza Blok D No. 9, Jl. Meruya Ilir raya , Srengeseng , Jakarta Barat 11630  
Phone : 6221 5890 1302 Email : unggulpp@upp.co.id Web : www.unggulpp.com

# **TRIPLE OFFSET BUTTERFLY VALVE**

## **Series - 7600**

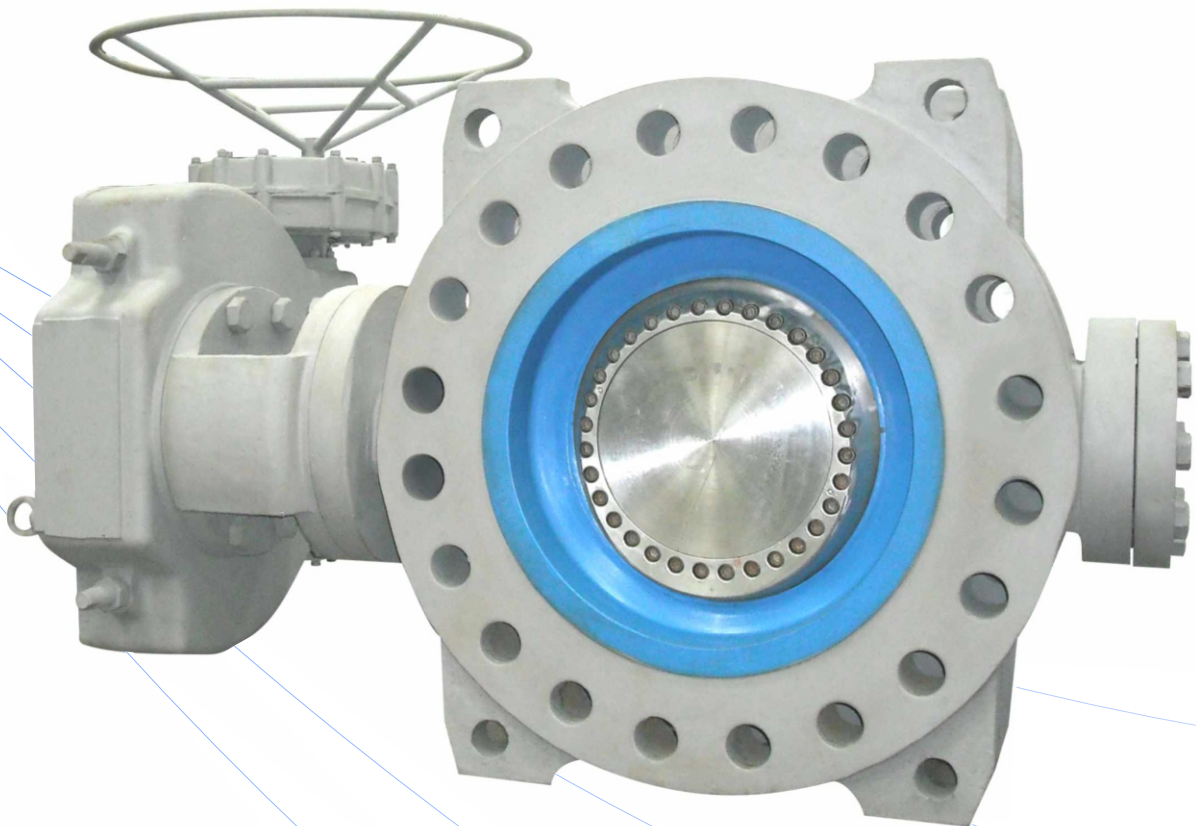

First issue Aug -2014 : Rev-0 Aug-2014



**UNGGUL  
PRAKARSA  
PRISMA**

Komplek Ruko Intercon Plaza Blok D No. 9, Jl. Meruya Ilir raya , Srengeseng , Jakarta Barat 11630  
Phone : 6221 5890 1302 Email : unggulpp@upp.co.id Web : www.unggulpp.com

## Foreword

Butterfly valves with single or double offset construction do not perform to the expectations when used for harsh & severe process applications, such as extreme temperature conditions, steam isolation, high operational frequency, abrasion services etc. Triple offset butterfly valves provide reliable & efficient performance under these harsh applications.

Series 7600 Triple offset metal seated Butterfly valves with unique seating geometry & design disc-shaft engagement provide high cycle life under extreme temperature conditions. With metal to metal tight shut-off characteristics eliminates.

all those problem like wear, seat deformation, abrasion, cold flow, crutches & leakage which are generally associated with soft seated butterfly valves. With extended performance features series 7600 Butterfly Valve are suitable for following application.:

### REFINERY

- Fuel oil storage isolation.
- Sulphur condenser switch valves
- Refinery desulphurization cooling water
- Flare gas, hydrogen gas & sour gas
- Dirty hot cracking gas.

### PULP & PAPER MILLS

- Steam isolation
- Alcohol process application
- Green, Red and Black liquors
- Lime, mud, slurries
- Boiler water
- Stock solutions

### STEEL MILLS

- Coke battery stop valves
- Recirculation pump discharge
- Compressor discharge

### CHEMICAL PLANTS

- Hydrogen gas
- Co2 Vapor
- Brine
- Propylene
- Steam
- Ethylene



## General specifications

<b>Size</b>	: DN 80 Thru DN 1200 3" Thru 48"
<b>Design &amp; manufacturing</b>	: Conforms to API 609 / BS 5155 / EN593 requirements
<b>Pressure Class</b>	: Pressure Rating 150# ANSI & 300# ANSI & 600# ANSI
<b>Working Temperature</b>	: -29 °C to + 538 °C With suitable combination of materials -100°C to + 700°
<b>Body Styles</b>	: Lug Types and Double Flanged
<b>Actuators</b>	: Manual Gear Operator, Pneumatic Actuator, Electrical actuator

## Applicable standards

<b>Design</b>	: Basic Design as per API 609 Calculations according to ASME SEC. VIII, EN-12516-2 ASME SEC. III, ANSI B16.34
<b>Face to Face Dimension</b>	: API 609 / EN 558-1 Series 13 & 20
<b>Body Flange</b>	: ANSI B16.5, ANSI 150# ,ANSI 300#
<b>Drilling</b>	PN-10,16,25,40
<b>Testing</b>	: API 598 ANSI / FCI 70.2 Cl. VI Leakage
<b>Marking</b>	: MSS-SP-25 / EN 99
<b>Quality</b>	: ISO 9001

## The laminated seal

The torque transmitted by the shaft to the disc generates uniform seating forces on the entire circumference of disc seal. The laminated seal flexes & gets energized in the direction of seal all over its entire circumference. The resiliency of the disc seal allows valve body and disc to expand or contract without producing any jamming effect under the fluctuating temperature range. The torque generated radial compressive force, equally distributed around the circumference, provides bidirectional tight shutoff.

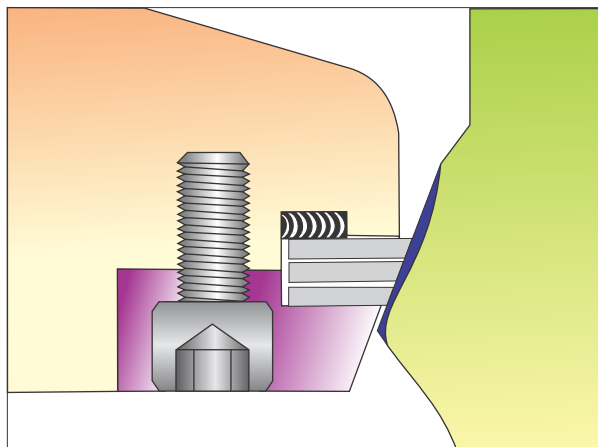

## Tripple Offset Geometry

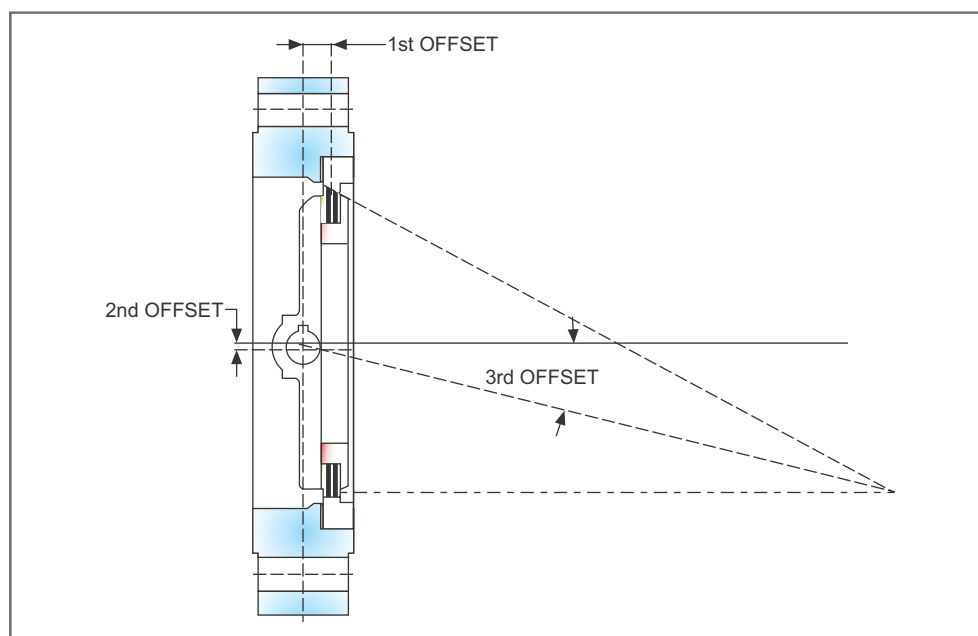

Series 7600 valves incorporate Triple offset disc configuration. With this configuration the disc seal makes contact with body seat, only at the final shutoff position without rubbing or galling with each other. Tight shut off is achieved with the torque on the shaft.

### FIRST OFFSET

The shaft is offset with seat axis. This offset makes complete seating contact around the entire seat. With this design the disc & seat remain in interference with each other for a larger rotation of valve disc, hence does not allow use of metal seats.

### SECOND OFFSET

The shaft centre is offset with the valve & pipe line. This offset creates a cam effect to the movement of disc while opening & closing of valve between disc seal & seat ring. The friction between seat & seal reduces to a great extent. This allows use metal seats & make double offset butterfly valves to a wider range of applications. However the metal seats need to be highly flexible to avoid jamming.

### THIRD OFFSET

The third offset is the axis of seat cone angle made inclined to the centre line of valve bore. The seat cone is offset to shaft centerline. This offset ensures 'last position' contact between disc seal & seat ring during closing & opening. The friction between seat & seal reduces to Zero. The triple offset mechanism is ideally suited for metal to metal seated valves providing bubble Tight shut off performance under high temperature & fire safe applications.

## Valve features

Torque generated metal to metal sealing provide bidirectional tight shutoff as per requirement of API 598 ,API 6D & FCI 70.2 ( class VI)

Triple offset geometry completely eliminates seat to seal rubbing action through out 90° disc rotation . The disc seal makes contact with the body seat only at the final shut off position.

Stellite hard facing on disc seal can be provided for abrasive services.

Complete metal construction including seal & seat with tight shut performance enable the design to be inherently fire safe.

Double blow out proof stem retention ensures greater safety and comply the requirements of API 609

Large diameter one piece shaft construction provides better disc alignment & smooth disc rotation between 0-90 °.The shaft is connected to the disc through keys & pin to absorb differential expansion due to temperature differential.

The shaft is guided with two long bearings which are hard chrome plated or Stellite depending on applications. Bearing protection seals are provides optionally for gas applications containing suspended particles.

Low emission gland packing: Shaft & stuffing box finished with excellent finish & live loaded packing provided low emission shaft sealing.

Stainless steel metal rings with in-between graphite layers are carefully assembled. The laminated resilient metal seals are suitable for temperature up to 1000 °F (538 °C)

Seal is mounted on the body always from the corrosive effects of the flowing media.

Both seat & seal are field replaceable with our special tools.

Mistake proof bolting system of seat & seal to facilitate the mounting of seat & seal in one & right position only.

Wide gaskets for seat & seal to eliminate leakage past the face of seat or seal under high temperature conditions.

In built truant mechanism of disc prevents decentralization of disc under high temperature & pressure conditions.

Rigid disc construction minimizes disc deflection.

Positive external valve position indication.

Heavy duty operator mounting bracket with ISO mounting facility for variety of actuator models.

Materials conforming to NACE available on request.

# Part Description

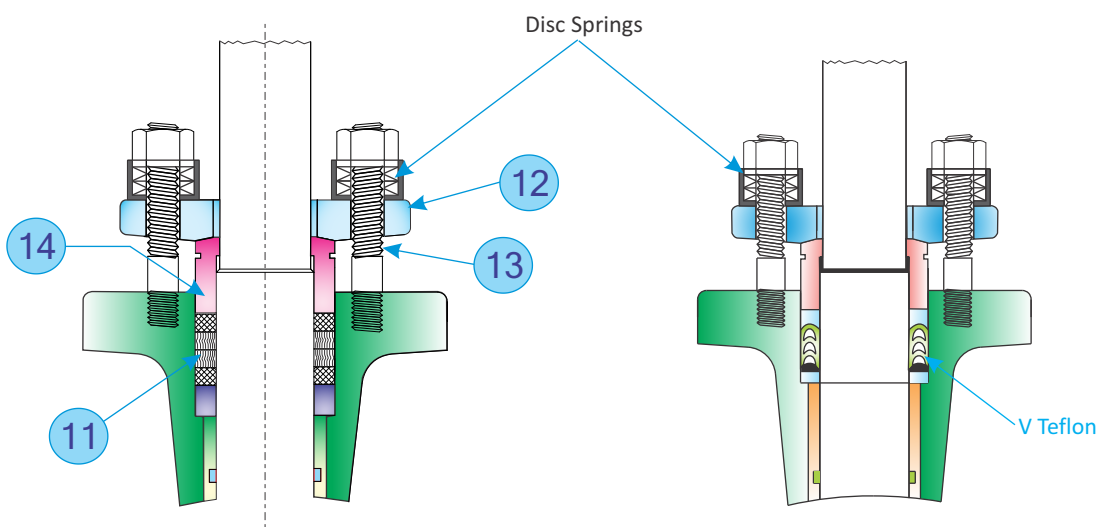
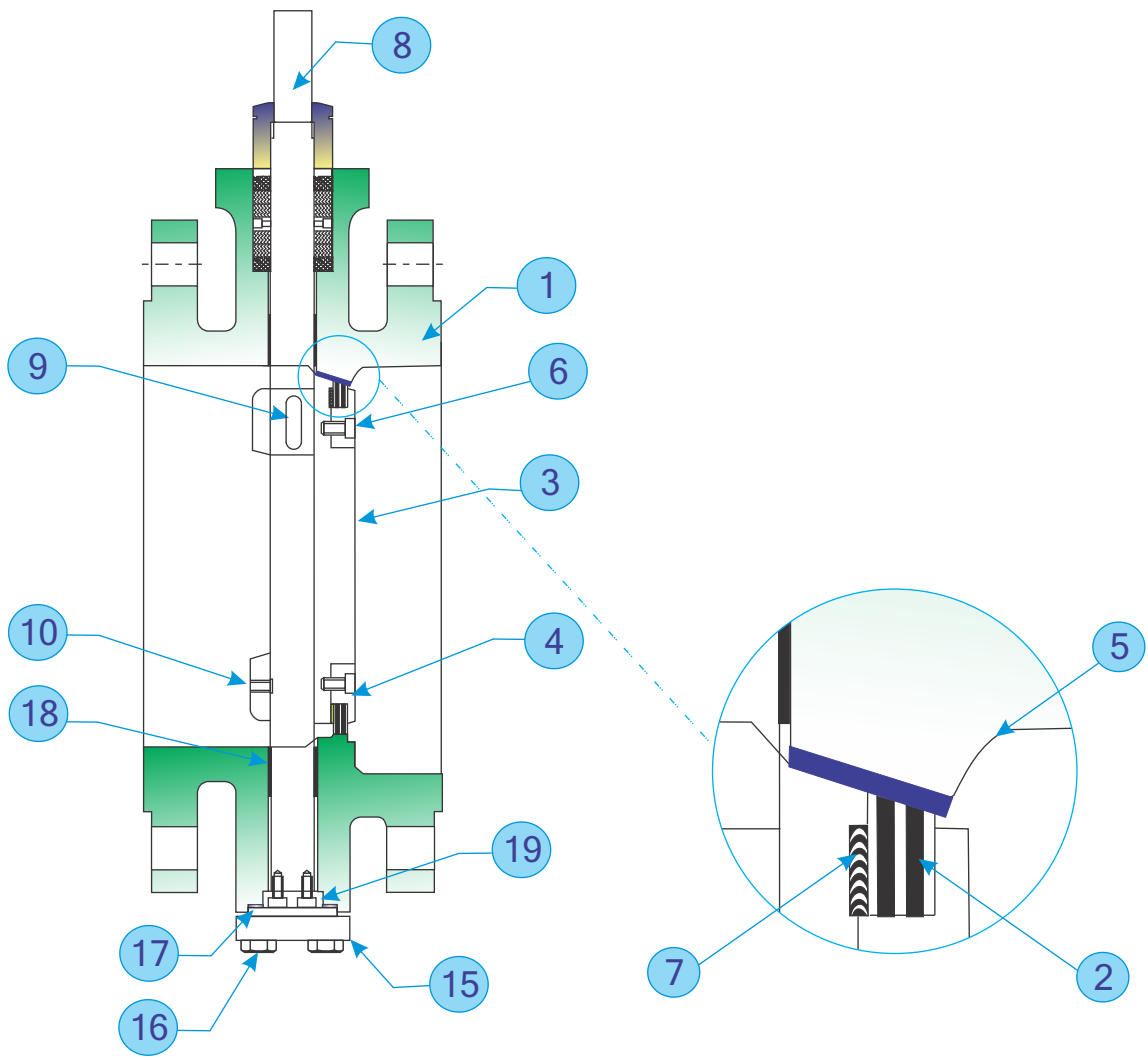

# Part Description

Sr. No.	Part Name	Body In "Carbon Steel"	Body In "stainless Steel"	Body In "Super Duplex"	Body In "Al. Bronze"
1	Body	ASTM A216 WCB	ASTM A351 CF8M	ASTM A590 GR. 6A	AL. BRONZE 2E BS 1400 AB 2
2	Disc Seal	SS316 + Graphite Laminated	SS316 + Graphite Laminated	SUPER DUPLEX UNS S32760 + Graphite (Laminated)	MONEL 400 + Graphite (Laminated)
3	Disc	ASTM A216 GR WCB	ASTM A351 CF8M	ASTM A S 90 GR. 6A	AL. BRONZE 2E BS 1400 AB2
4	Seal Retainer	Carbon Steel	ASTM A351 CF8M	SUPER DUPLEX UNS S32760	AL. BRONZE 2E BS 1400 Ab2
5	Body Seat Overlay	Stellite	Stellite	-	-
6	Seal Retainer Bolt	SS 304	SS 304	SS 304	SS 304
7	Seal Gasket	SS Spiral Wound Graphite Filled	SS Spiral Wound Graphite Filled	SS Spiral Wound Graphite Filled	SS Spiral Wound Graphite Filled
8	Shaft	SS316 / SS 410/17-4PH	Ss316	SUPER DUPLEX UNS S32760	MONEL K 500
9	Disc Key	SS316 / SS410/17-4PH	SS316	SUPER DUPLEX UNS S32760	MONEL K 500
10	Screw	SS316	SS316	SUPER DUPLEX UNS S32760	MONEL K 500
11	Gland Packing	Graphite (2)	Graphite	Graphite (2)	Graphite (2)
12	Gland Flange	Carbon Steel	SS316	SS 316	SS 316
13	Packing Studs	SS304	SS304	SS 304	SS 304
14	Gland bush	SS316	SS316	SS 316	SS 316
15	Bottom Cover	Carbon Steel	Ss316	SUPER DUPLEX UNS S32760	AL. BRONZE 2E BS 1400 Ab2
16	Bolts	SS 304	SS 304	SS 304	SS 304
17	Gasket	SS Spiral Wound Graphite Filled	SS Spiral Wound Graphite Filled	SS Spiral Wound Graphite Filled	SS Spiral Wound Graphite Filled
18	Bearings	SS 410	SS 410	Bronze	Bronze
19	Thrust Washer	Bronze	Bronze	Bronze	Bronze

1) Stellite Facing on Body as seating on request.

2) V-PTFE packing for Temperature less than 200°C

## Low emission gland packing

Dembla provides live loading gland packing arrangement as a standard feature, for series 7600 butterflys.

- 1) Short packing chamber
- 2) Stem bearings are longer enough to take side loads of stem so that its movement remains true concentric. This facilitates maximum effective shaft sealing.
- 3) Disc springs in the gland flange provide constant live loading on packing.

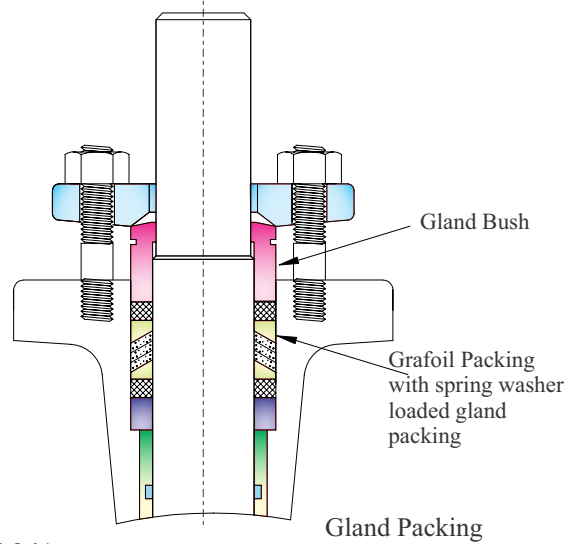

### PRESSURE TEMPERATURE RATING ( B 16.34 )

Temperature °F	Class 150	Class 300	Class 600	Temperature °C
	A216 GR WCB	A216 GR WCB	A216 GR WCB	
-20 to 100	285	740	1480	-29 TO 37.7
200	260	675	1350	93.3
300	230	655	1315	148.8
400	200	635	1270	204.4
500	170	600	1200	260
600	140	550	1095	315.5
650	125	535	1075	343.3
700	110	535	1065	371
750	95	505	1010	399
800	80	410	825	426.6
850	65	270	535	454.4
900	50	170	345	482.2
950	35	105	205	510
1000	20	50	105	537.8
1050	-	-	-	565.6
1100	-	-	-	593.3
1150	-	-	-	621
1200	-	-	-	648.9

Temperature °F	Class 150	Class 300	Class 600	Temperature °C
	A351 GR CF8M	A351 GR CF8M	A351 GR CF8M	
-20 to 100	275	720	1440	-29 TO 37.7
200	240	620	1240	93.3
300	215	560	1120	148.8
400	195	515	1030	204.4
500	170	480	955	260
600	140	450	905	315.5
650	125	445	890	343.3
700	112	430	865	371
750	95	425	845	399
800	80	415	830	426.6
850	65	405	810	454.4
900	50	395	790	482.2
950	35	385	775	510
1000	20	365	725	537.8
1050	20(1)	360	720	565.6
1100	20(1)	325	645	593.3
1150	20(1)	275	550	621
1200	20(1)	205	410	648.9

Permissible but not recommended for prolonged usage above 800 °F (426.6 °C)  
 (1) Flanged end rating terminates at 1000 °F (537.8 °C)



### Cv VALUES (usgpm)

Valve Size		150#	
inch	mm	60°	90°
3	80	82	165
4	100	200	400
5	125	325	650
6	150	525	1050
8	200	1100	2200
10	250	1650	3300
12	300	2550	5100
14	350	2900	5800
16	400	4000	800
18	450	5250	10500
20	500	7000	14000
24	600	10800	21600
28	700	14700	29400
32	800	19200	38400
36	900	27750	55500
40	1000	34250	68500
48	1200	54150	108300

### Basic Flow characteristic curve

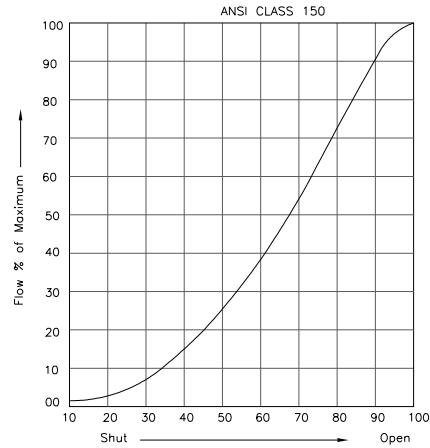

Valve Size		300#	
inch	mm	60°	90°
3	80	82	165
4	100	200	400
5	125	325	650
6	150	525	1050
8	200	900	1800
10	250	1575	3150
12	300	2375	4750
14	350	2600	5200
16	400	3450	6900
18	450	4650	9300
20	500	5650	11300
24	600	9250	18500
28	700	12590	25180
32	800	16444	32888
36	900	23750	47500
40	1000	29320	58640
48	1200	41840	83680

### Torque Values (NM) rP in Bar

Valve Size		5	10	15	20	30	40	51
inch	mm							
3	80	34	47	63	80	114	149	189
4	100	61	77	103	142	200	260	329
5	125	105	137	183	229	319	414	524
6	150	189	280	373	454	623	793	998
8	200	201	332	442	603	883	1206	1546
10	250	354	542	722	960	1389	1868	2388
12	300	637	822	1096	1357	1889	2437	3077
14	350	1015	1344	1792	2247	3140	4082	5165
16	400	1050	1610	2146	2852	4126	5552	7097
18	450	1456	2030	2706	3464	4915	6476	8228
20	500	2050	2720	3626	4543	6368	8282	10480
24	600	3587	4593	6124	7548	10481	13490	17266
28	700	4882	6248	8334	10270	14269	18361	23520
32	800	6370	8161	10885	13414	18637	23982	30720
36	900	8060	10329	13776	16977	23587	30352	38880
40	1000	9952	12752	17008	20960	29120	37472	48000
48	1200	14330	18363	24491	30182	41933	53960	69120

The figures shown above are for actuator sizing & safety factor is already included.  
The valves can be used for preferred direction as well as reverse direction.

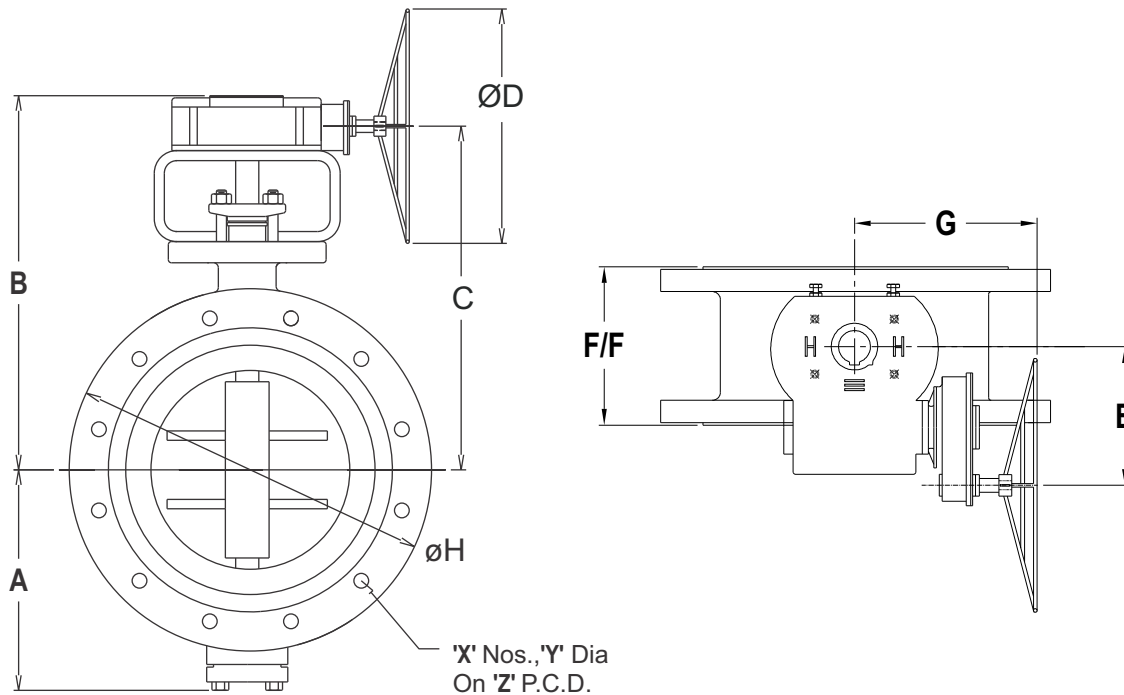

**Flanged Valves- ANSI - 150#**

Size in mm	GEAR	A	B	C	ØD	E	F/F	G	H	X	Y	Z
3 DN80	TMWG 225	97	266	241	175	39	114	195	190.5	4	19	152
4 DN100	TMWG 225	117	319	283	175	39	127	195	228.5	8	19	190.5
6 DN150	TMWG 500	147	317	317	250	56	140	240	279.5	8	22	241
8 DN200	TMWG 750	225	389	357	350	66.5	152	285	343	8	22	298
10 DN250	TMWG 1500	245	426	385	500	85.25	165	360	406.5	12	25	362
12 DN300	TMWG 1500	285	498	455	500	85.25	178	360	482.5	12	25	432
14 DN350	TMWG 2750	305	545	525	500	119.25	190	355	533.5	12	28.5	476
16 DN400	TMWG 3400	345	583	525.5	600	131.5	216	330	597	16	28.5	540
18 DN450	WG 55/S	380	618	540	500	193.5	222	393	635	16	32	578
20 DN500	WG 55/S	390	670	603	500	193.5	229	393	698.5	20	32	635
24 DN600	WG 110/S	460	790	700	500	300.5	267	464	813	20	35	749
28 DN700	WG 75-S25	549	830	738	700	334.5	292	530	927.1	28	35	863.6
32 DN800	WG 75-S40	580	938	848	700	382.5	318	575	1060.45	28	41.5	977.9
36 DN900	WG 75-S40	641	979	995	700	382.5	330	575	1168.5	32	41.5	1085.85
40 DN1000	WG 100-S40	650	1250	1100	800	459	410	610	1289.05	36	41.5	1200.15
48 DN1200	WG 100-S 5	820	1100	1220	800	481.73	470	605	1511.3	44	41.5	1422.4

**Flanged Valves- ANSI - 300#**

Size in mm	GEAR	A	B	C	ØD	E	F/F	G	H	X	Y	Z
3 DN80	TMWG 225	92	250	216	175	39	180	195	209.5	8	22	168
4 DN100	TMWG 500	148	300	267	250	56	190	240	254	8	22	200
6 DN150	TMWG 1500	190	367	326	500	85.25	210	360	317.5	12	22	270
8 DN200	TMWG 1750	220	416	374	600	87.75	230	332	381	12	25.4	330
10 DN250	TMWG 2750	250	458	408	500	119.25	250	355	444.5	16	28.5	387
12 DN300	TMWG 3400	290	515	455	600	131.5	270	330	520.7	16	32	451
14 DN350	T-450/S	320	550	481	500	212.5	290	413	584.2	20	32	514
16 DN400	T-725/S	402	620	555	500	225	310	410	647.7	20	35	571.5
18 DN450	WG 110/S	427	675	685	500	300.5	330	464	711.2	24	35	629
20 DN500	WG 75/S 25	450	720	626	700	334.5	350	530	774.7	24	35	686
24 DN600	WG 75/S 40	550	773	685	700	382.5	390	575	914.4	24	41	813
28 DN700	WG 100S 40	603	873	797	800	459	430	610	1035.05	28	44.5	939.8
32 DN800	WG 100S 5	624	982	892	950	602.73	470	605	1149.35	28	51	1054.1
36 DN900	WG 100S 6	780	1040	940	800	493.70	510	370	1270	32	54	1168.4
40 DN1000	WG 120S 5	735	1275	1325	950	602.73	550	552	1238.25	32	45	1155.7
48 DN1200	WG 120S 8	920	1840	1290	950	602.73	630	770	1466.85	32	45	1371.6

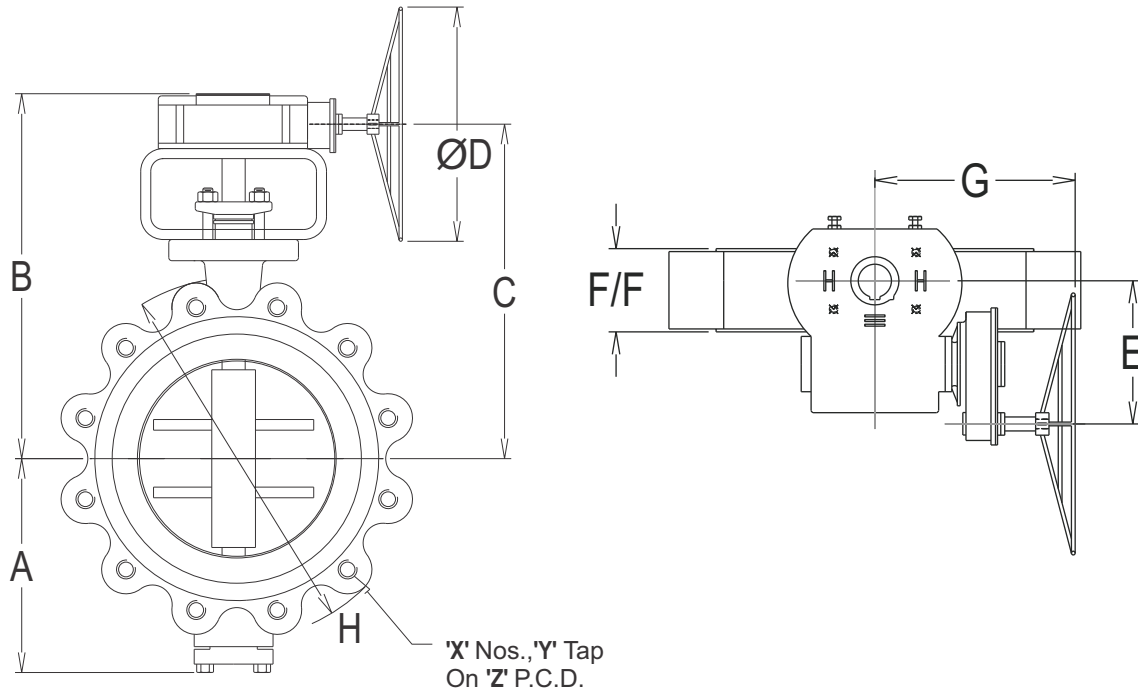

**Lug Valves- ANSI - 150#**

Size in mm	GEAR	A	B	C	ØD	E	F/F	G	H	X	Y	Z
3 DN80	TMWG 225	97	265	240	175	39	46	195	190.5	4	5/8"UNC	152
4 DN100	TMWG 225	122	278	253	175	39	54	195	228.5	8	5/8"UNC	190.5
6 DN150	TMWG 500	155	340	310	250	56	57	240	279.5	8	3/4"UNC	241
8 DN200	TMWG 750	210	385	335	350	66.5	64	285	343	8	3/4"UNC	298
10 DN250	TMWG 1500	240	456	415	500	85.25	71	360	406.5	12	7/8"UNC	362
12 DN300	TMWG 1500	285	516	475	500	85.25	81	360	482.5	12	7/8"UNC	432
14 DN350	TMWG 2750	300	545	498	500	119.25	92	355	533.5	12	1"UNC	476
16 DN400	TMWG 3400	350	583	540	600	131.5	102	330	597	16	1"UNC	540
18 DN450	WG 55/S	385	625	560	500	193.5	114	393	635	16	1.1/8"X8"UN	578
20 DN500	WG 55/S	400	650	590	500	193.5	127	393	698.5	20	1.1/8"X8"UN	635
24 DN600	WG 110/S	460	790	710	500	300.5	154	464	813	20	1.1/4"X8"UN	749
28 DN700	WG 75-S25	549	819	750	700	334.5	165	530	927.1	28	1.1/4"X8"UN	863.6
32 DN800	WG 75-S40	605	938	848	700	382.5	190	575	1060.45	28	1.1/2"X8"UN	977.9
36 DN900	WG 75-S40	630	854	854	700	382.5	203	575	1168.5	32	1.1/2"X8"UN	1085
40 DN1000	WG 100-S40	710	1250	1300	800	459	216	610	1289.05	36	1.1/2"X8"UN	1200
48 DN1200	WG 100-S 5	862	1928	1279	800	481.73	254	605	1511.3	44	1.1/2"X8"UN	1422

**Lug Valves- ANSI - 300#**

Size in mm	GEAR	A	B	C	ØD	E	F/F	G	H	X	Y	Z
3 DN80	TMWG 225	92	260	235	175	39	48	195	290.5	8	3/4"UNC	168
4 DN100	TMWG 225	150	285	260	250	56	54	240	254	8	3/4"UNC	200
6 DN150	TMWG 500	174	352	324	500	85.25	59	360	317.5	12	3/4"UNC	270
8 DN200	TMWG 750	239	394	357	600	87.75	73	332	381	12	7/8"UNC	330
10 DN250	TMWG 1500	278	451	410	500	110.25	83	355	444.5	16	1"UNC	387
12 DN300	TMWG 1500	330	496	455	600	131.5	92	330	520.7	16	1.1/8"X8"UN	451
14 DN350	TMWG 2750	320	530	520.5	500	212.5	117	413	584.2	20	1.1/8"X8"UN	514
16 DN400	TMWG 3400	408	637	577	500	225	133	410	647.7	20	1.1/4"X8"UN	571.5
18 DN450	WG 55/S	445	680	540	500	300.5	149	464	711.2	24	1.1/4"X8"UN	629
20 DN500	WG 55/S	510	955	690	700	334.5	159	700	774.7	24	1.1/4"X8"UN	686
24 DN600	WG 110/S	566	830	740	700	382.5	181	575	914.4	24	1.1/2"X8"UN	813

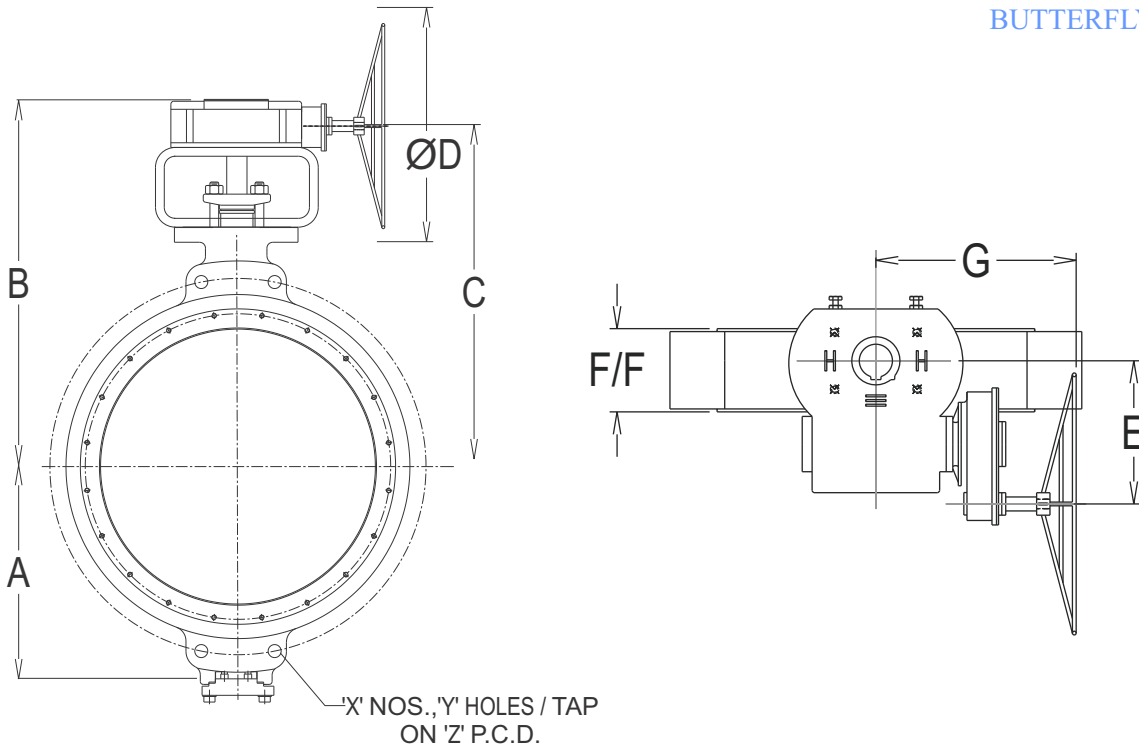

**Wafer Valve - ANSI - 150#**

Size in mm	GEAR	A	B	C	ØD	E	F/F	G	X	Y	Z
3 DN80	TMWG 225	97	265	240	175	39	46	195	-	-	-
4 DN100	TMWG 225	122	278	253	175	39	54	195	-	-	-
6 DN150	TMWG 500	155	340	310	250	56	57	240	-	-	-
8 DN200	TMWG 750	210	385	335	350	66.5	64	285	2+2	22.2	298
10 DN250	TMWG 1500	240	456	415	500	85.25	71	360	2+2	25.4	362
12 DN300	TMWG 1500	285	516	475	500	85.25	81	360	2+2	25.4	432
14 DN350	TMWG 2750	300	545	498	500	119.25	92	355	2+2	28.6	476
16 DN400	TMWG 3400	350	583	540	600	131.5	102	330	2+2	28.6	540
18 DN450	WG 55/S	385	625	560	500	193.5	114	393	2+2	31.8	578
20 DN500	WG 55/S	400	650	590	500	193.5	127	393	2+2	1.1/8"X8"UN	635
24 DN600	WG 110/S	460	790	710	500	300.5	154	464	2+2	1.1/4"X8"UN	749
28 DN700	WG 75-S25	549	819	750	700	334.5	165	530	4+4	1.1/4"X8"UN	863.6
32 DN800	WG 75-S40	605	938	848	700	382.5	190	575	4+4	1.1/2"X8"UN	977.9
36 DN900	WG 75-S40	630	854	854	700	382.5	203	575	4+4	1.1/2"X8"UN	1085
40 DN1000	WG 100-S40	710	1250	1300	800	459	216	610	4+4	1.1/2"X8"UN	1200
48 DN1200	WG 100-S 5	862	1928	1279	800	481.73	254	605	4+4	1.1/2"X8"UN	1422

**Wafer Valve - ANSI - 300#**

Size in mm	GEAR	A	B	C	ØD	E	F/F	G	H	X	Y	Z
3 DN80	TMWG 225	92	260	235	175	39	48	195	290.5	8	3/4"UNC	168
4 DN100	TMWG 225	150	285	260	250	56	54	240	254	8	3/4"UNC	200
6 DN150	TMWG 500	174	352	324	500	85.25	59	360	317.5	12	3/4"UNC	270
8 DN200	TMWG 750	239	394	357	600	87.75	73	332	381	12	7/8"UNC	330
10 DN250	TMWG 1500	278	451	410	500	110.25	83	355	444.5	16	1"UNC	387
12 DN300	TMWG 1500	330	496	455	600	131.5	92	330	520.7	16	1.1/8"X8"UN	451
14 DN350	TMWG 2750	320	530	520.5	500	212.5	117	413	584.2	20	1.1/8"X8"UN	514
16 DN400	TMWG 3400	408	637	577	500	225	133	410	647.7	20	1.1/4"X8"UN	571.5
18 DN450	WG 55/S	445	680	540	500	300.5	149	464	711.2	24	1.1/4"X8"UN	629
20 DN500	WG 55/S	510	955	690	700	334.5	159	700	774.7	24	1.1/4"X8"UN	686
24 DN600	WG 110/S	566	830	740	700	382.5	181	575	914.4	24	1.1/2"X8"UN	813

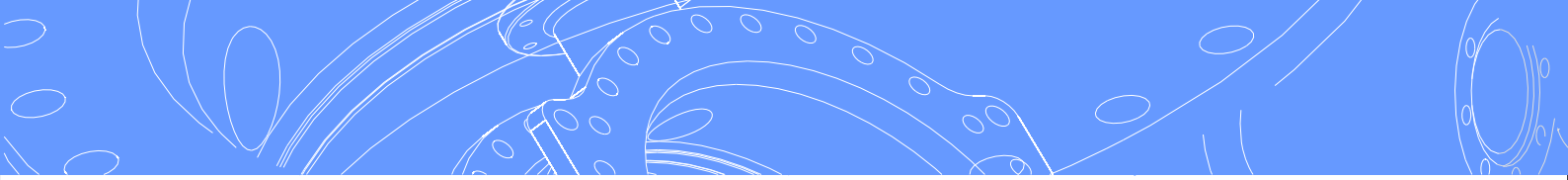

Komplek Ruko Intercon Plaza Blok D No. 9, Jl. Meruya Ilir raya , Srengeseng , Jakarta Barat 11630  
Phone : 6221 5890 1302 Email : unggulpp@upp.co.id Web : www.unggulpp.com