



**UNGGUL
PRAKARSA
PRISMA**

Komplek Ruko Intercon Plaza Blok D No. 9, Jl. Meruya Ilir raya , Srengeseng , Jakarta Barat 11630
Phone : 6221 5890 1302 Email : unggulpp@upp.co.id Web : www.unggulpp.com

FLOATING BALL VALVE

SERIES - 8100

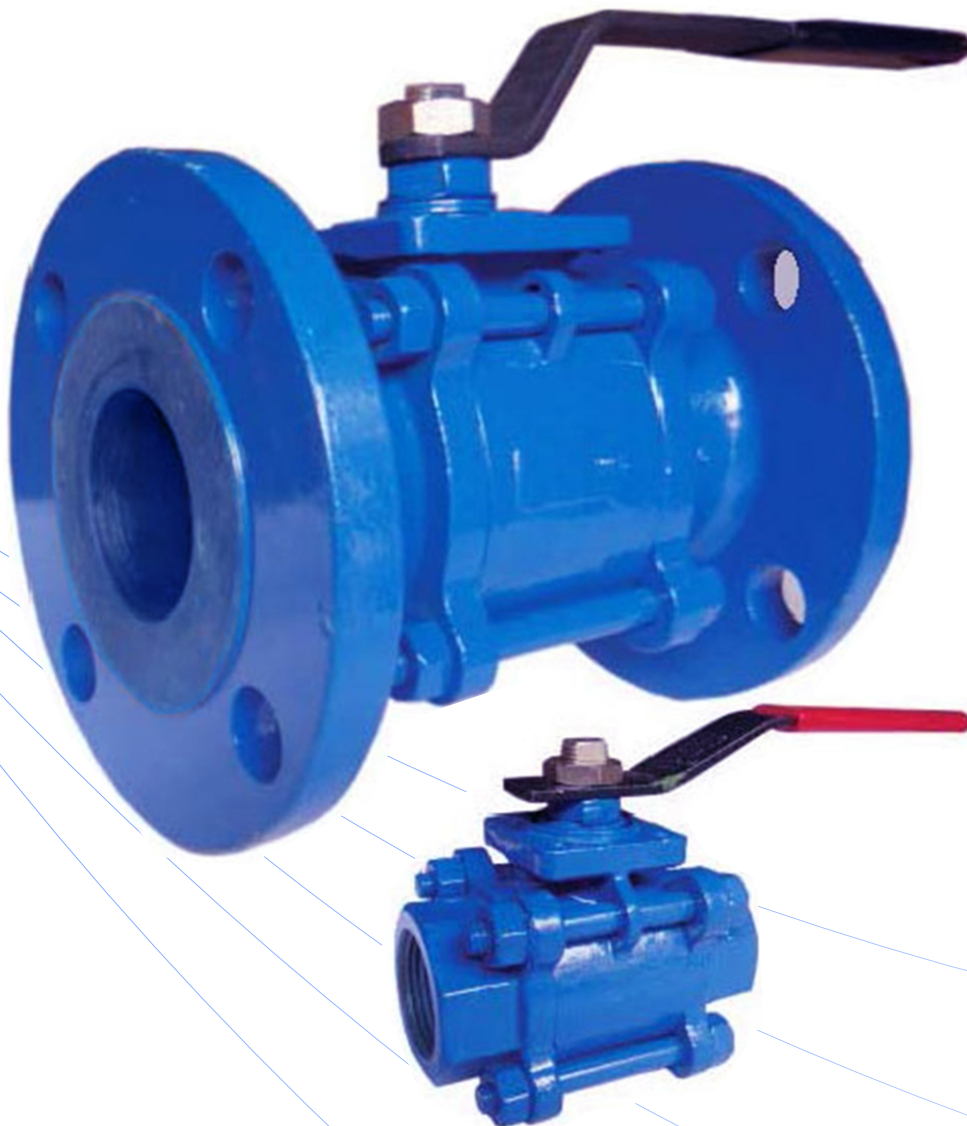

First issue Aug -2014 : Rev-1 Aug-2021



**UNGGUL
PRAKARSA
PRISMA**

Komplek Ruko Intercon Plaza Blok D No. 9, Jl. Meruya Ilir raya , Srengeseng , Jakarta Barat 11630

Phone : 6221 5890 1302 Email : unggulpp@upp.co.id Web : www.unggulpp.com

Product Range

Construction	End Connection	Port	Rating Class	SIZES												
				INCH	1/2"	3/4"	1"	1 1/2"	2"	2 1/2"	3"	4"	6"	8"		
				MM	15	20	25	40	50	65	80	100	150	200		
Single Piece	Flanged	Reduced	150	■	■	■	■	■	■	■	■	■	■	■	■	■
Two Piece	Flanged	Full / Reduced	150/300/600	■	■	■	■	■	■	■	■	■	■	■	■	■
3 -Way T Port	Flanged	Full	150/300	■	■	■	■	■	■	■	■	■	■	■	■	■
3 -Way L Port	Flanged	Full	150/300	■	■	■	■	■	■	■	■	■	■	■	■	■

Features

Live Loaded Gland Packing

Graphite Packing are provided as standard taking care of Fire Safe Design Condition. Belleville Springs Washers are used to achieve live loading which protects Gland loosening under vibrations & shock conditions.

Antistatic Device

To ensure Electrical Continuity between the Stem and Ball and Body all Valves are provided with Antistatic device as an integral part of Floating Ball Valves.

Blow Out Proof Stem

Stem is Designed to include a collar to provide protection against Blow Outs.

Double 'D' Stem to Lever Connection

Stems are Designed to have Double 'D' Connection at the top for Lever Fixing. This feature eliminates possibility of Lever Assembly in the wrong direction as the Lever indicates the Valve Position once installed on the line.

Equalized Cavity Pressure

The Pressure equalization hole at the top of the Ball combined with Seat Design are Engineered to maintain the Pressure balance in the line & in the Body Cavity irrespective of Valve Position

Locking Device

Locking devices are provided on all Valves with both Lever Operator and Gear Operator.

Integral Actuator Mounting Pad

Design Features

Stem Seal

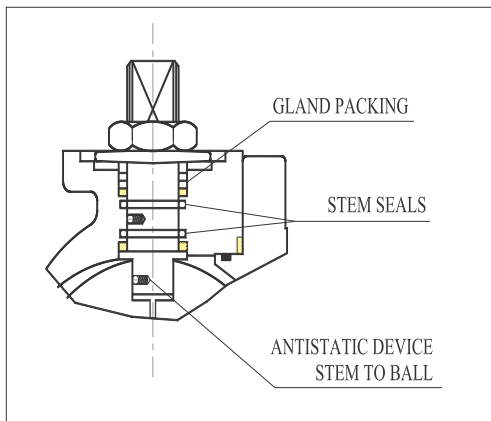

We provide multiple stem sealing for high degree of sealing.

Fire Safe

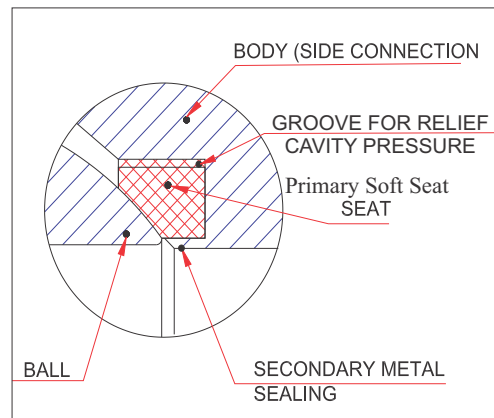

Fire safe design as per API 607, API 6FA

Body Sealing

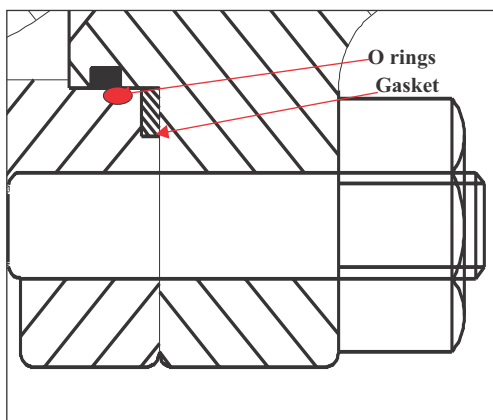

We provide O ring & Gasket between body and side connection for effective sealing.

ISO Pad



We provide mounting pad for actuator/gear operated mounting as per ISO 5211

Cavity Pressure Relief :-

Some line fluid is usually left trapped inside the ball-body cavity. This fluid can expand under the influence of high ambient and line temperature. An abnormal increase of such cavity pressure may sometimes damage the valve seats or balls, unless the valve has an adequate cavity pressure relief provision. General solution for floating ball valve is to provide hole in the ball-stem slot to equalize the pressure behind the valve cavity.

Seats with pressure-relieving seats :-

In floating ball valves the line pressure forces the ball to the downstream seat, the seat flexes and creates the seal. The upstream seat is forced forward, allowing the pressure to penetrate from behind through the grooves and into the body cavity, which relieving the load and prevent the seat damage.

Design Features

Lipseal Design (Optional)

Lipseal is the spring-energized seal including Elgiloy or Inconel spring and PTFE jacket. It's effective in a wide range of application, such as high resistance to corrosive chemical media, high sour gas, low temperature or cryogenic service.

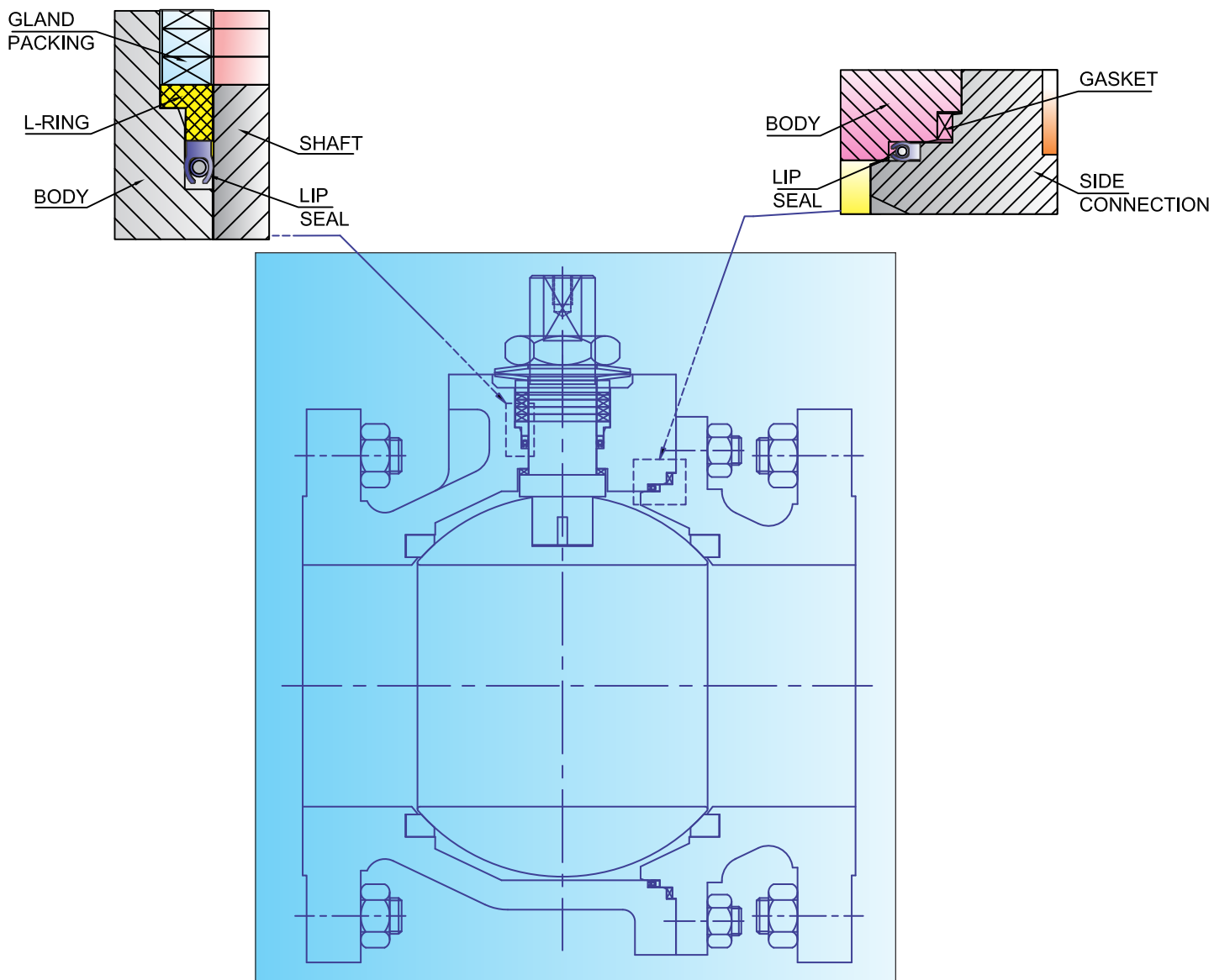

Design & Testing Standards

Design Standard:.

- ASME B16.34
- API 6D
- BS -5351
- ISO 17292
- ISO 5211 (Mounting Pad)

End Connection Standards:.

- Face to Face : ASME B16.10 / API 6D
- Flange Dimensions : ASME B16.5, EN 1092 , JIS B 2220 ,
- Butt weld End Dimensions : ASME B16.25,
- Socketweld End Dimensions : ASME B16.11
- Screwed End Dimensions : ASME B 16.11

Testing Standards

- Pressure Testing : API 598, API 6D, ASME/FCI 70.2, EN 12266-1, ISO 5208
- Fire Testing : API 607 / API 6FA
- Nace Requirements : MR 01-75
- Fugitive Emission Testing : ISO 15848-2

Valve Construction

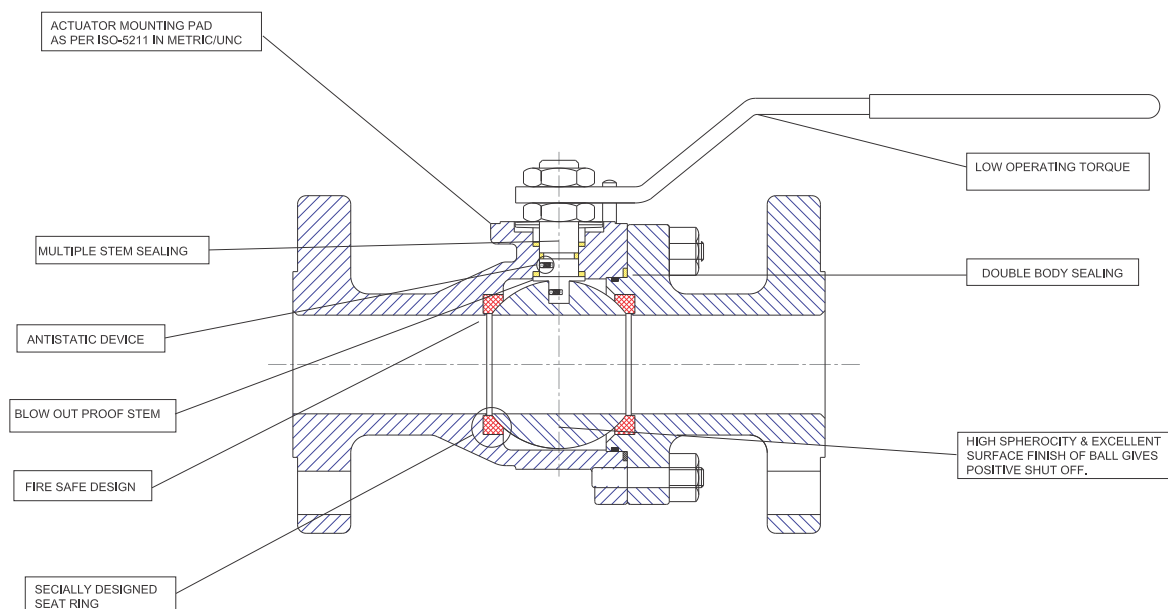

Material Options

Part Name	Casting	Forgings
VALVE BODY	A 216 WCB, A 351 CF8	A 105, A 350 LF2 , A 350 LF3, A 182 F6a
SIDE CONNECTION	A 351 CF8M, A 351 CF3	A 182 F 304, A 182 F 316, A 182 F 316LN
BALL	A 351 CF3M, A 352 LCB A 217 CA 15, A 148 C95000 (AL. BRONZE) (DUPLEX) SUPER DUPLEX ALLOY 20 HAST C 276	A 182 F 321, A 182 F 44(6% MO) A 150 C 63000 (Al. Bronze), A 182 F 51 (Duplex S.S.) INCONEL 625 (UNS N 06625) INCONEL 825 (UNS N 8825) MONEL K 400 (UNS N 04400) MONEL K 500 (UNS N 05500)
STEM	A 105, A 350 LF2 , A 350 LF3, A 182 F6a A 182 F 304, A 182 F 316, A 182 F 316LN A 182 F 321, A 182 F 44(6% MO) A 150 C 63000 (Al. Bronze), A 182 F 51 (Duplex S.S.) INCONEL 625 (UNS N 06625) INCONEL 825 (UNS N 8825) MONEL K 400 (UNS N 04400) MONEL K 500 (UNS N 05500)	
SOFT SEAT	PTFE , RPTFE, NYLON 12-G, DEVLON , PEEK	
SEALS	NITRIL, EPDM, VITON B, VITON GLT	
GASKET	PTFE, RPTFE, GRAPHITE	
STUDS/BOLTS & NUTS	A 193 GR. B7 A 193 GR. B7M A 320 L7 A 320 L7M A 320 L43 A 193 GR. B8 A 193 GR. B8M	A 194 GR. 2H A 194 GR. 2HM A 194 GR. 7 or GR.4 A 194 GR 7M A 194 GR. 7M A 194 GR. 8 A 194 GR. 8M

Parts Illustrated

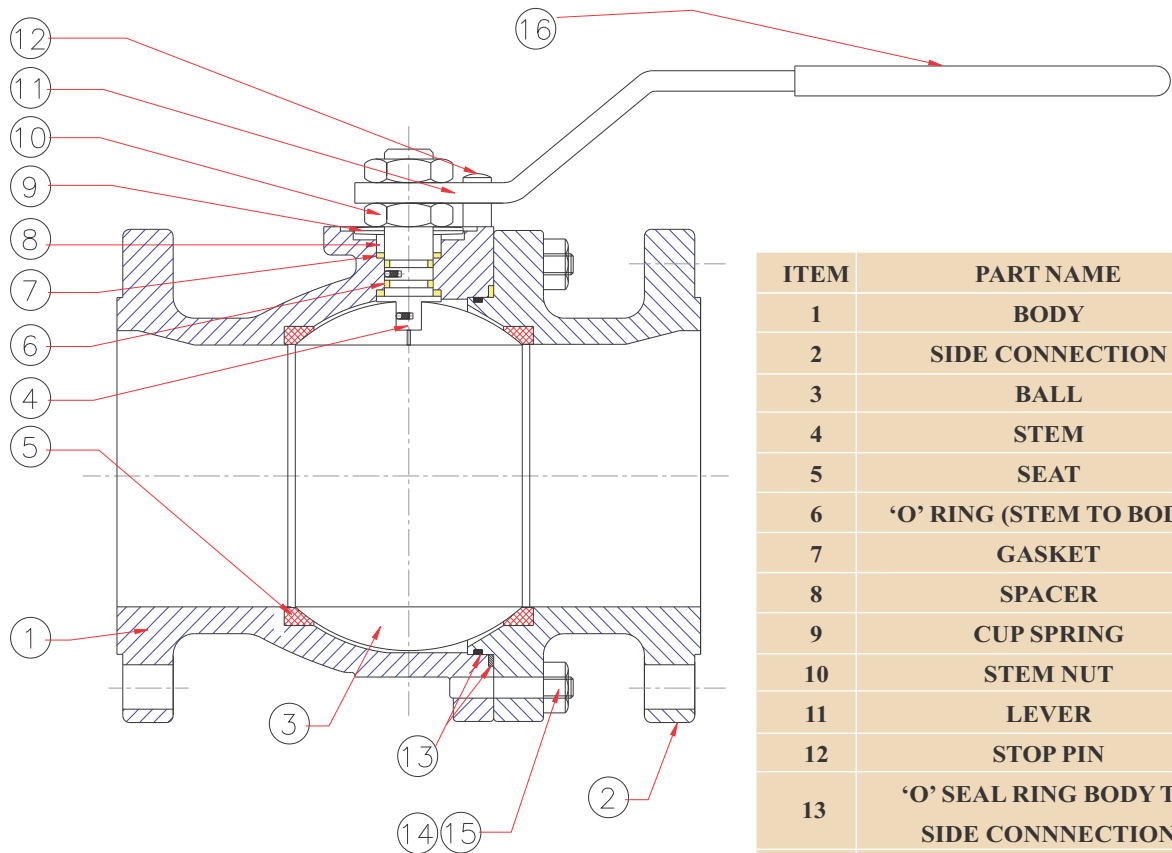

ITEM	PART NAME
1	BODY
2	SIDE CONNECTION
3	BALL
4	STEM
5	SEAT
6	'O' RING (STEM TO BODY)
7	GASKET
8	SPACER
9	CUP SPRING
10	STEM NUT
11	LEVER
12	STOP PIN
13	'O' SEAL RING BODY TO SIDE CONNECTION
14	STUD
15	NUT
16	HANDLE

Two Piece Ball Valve

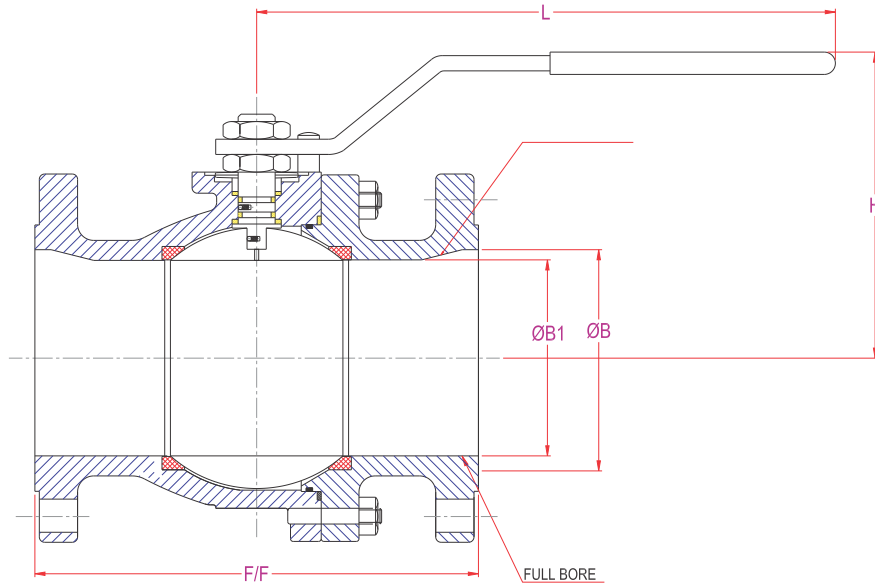

ASME 150 Full Bore

Size DN	ASME 150 Full Bore								(SP)/(LP)	(SP*)/(LP)
Class	15	20	25	40	50	65	80	100	150	200
B	14	19	25	38	50	62	76	102	152	198/203
F/F	108.0	117.0	127.0	165.0	178	190.0	203	229	267/394	292/457
H	94	100	128	146	176	188	218	243	270	-
L	180	180	210	210	290	290	400	450	990	-
ISO 5211 MTG	F05	F05	F05	F05	F07	F07	F10	F10	F12	F14
WT (Kg)	2.0	2.6	3.6	6.0	10	16	20	38	70/92	140/150

ASME 150 Reduced Bore

Size DN	ASME 150 Reduced Bore								(SP)	(SP)
Class	15	20	25	40	50	65	80	100	150	200
B1	9	14	19	32	38	50	62	76	102	152
B	14	19	25	38	50	62	76	102	152	203
F/F	108.0	117.0	127.0	165.0	178.0	190.0	203.0	229	267	292
H	62	94	102	128	148	176	189	218	246	276
L	104	180	180	210	210	290	290	450	450	990
ISO 5211 MTG	F03	F05	F05	F05	F05	F07	F10	F10	F10	F12
WT (Kg)	1.3	2.3	2.8	4.0	8.1	13.5	17.4	28.1	44.2	79

ASME 300 Full Bore

Size DN	ASME 300 Full Bore								(SP/LP)	(SP)
Class	15	20	25	40	50	65	80	100	150	200
B	14	19	25	38	50	62	76	102	152	203
F/F	140.5	152.0	165.0	190.0	216	241.0	283	305	403.4	419.0/502
H	92	100	126	149	180	189	222	246	-	-
L	180	180	210	210	290	290	450	450	-	-
ISO 5211 MTG	F05	F05	F05	F05	F07	F07	F10	F10	F14	F14
WT (Kg)	2.7	3.6	5	9.5	15	25	32	52	115	185/195

ASME 300 Reduced Bore

Size DN	ASME 300 Reduced Bore									(SP)
Class	15	20	25	40	50	65	80	100	150	200
B1	9	14	19	32	38	50	62	76	102	152
B	14	19	25	38	50	62	76	102	152	203
F/F	140.5	152.0	165.0	190.0	216	241.0	283	305	403.4	419.0
H	62	92	102	128	149	180	189	222	248	-
L	104	180	180	210	210	290	290	450	450	-
ISO 5211 MTG	F03	F05	F05	F05	F05	F07	F07	F10	F10	F14
WT (Kg)	1.8	3.3	4.2	8.4	11.6	20.0	22	38	87	142.5

Two Piece Ball Valve

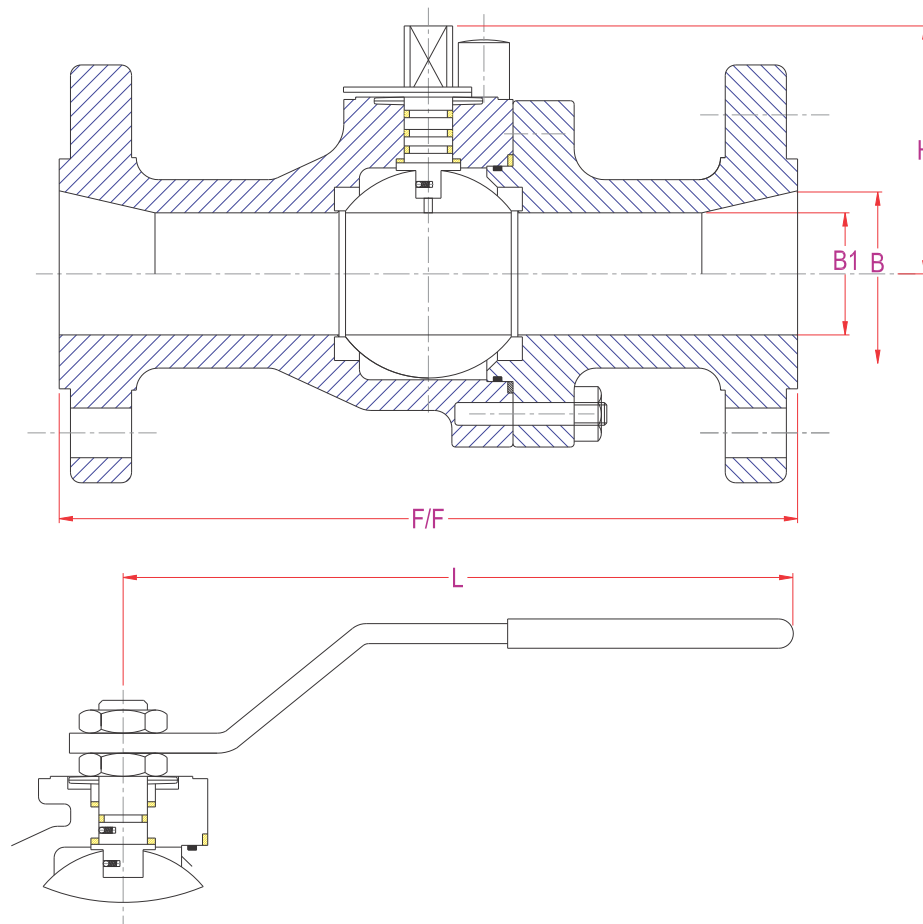

FOR 1/2" & 3/4"

ASME 600 FULL BORE / REDUCED BORE

CLASS	ASME 600 FULL BORE / REDUCED BORE															
	SIZE	DN 15		DN 20		DN 25		DN 40		DN 50		DN 80		DN 100		DN 150
	FB	FB	RB	FB	RB	FB	RB	FB	RB	FB	RB	FB	RB	FB	RB	RB
B x B1	14	19	14	25	19	38	25	50	38	76	50	102	76	152	102	
F/F	165.0	190.5	190.5	216.0	216.0	241.3	241.3	292.0	292.0	355.6	355.6	432.0	432.0	559		
H	69.0	69.0	69.0	65.0	68.0	90.0	68.0	108.0	93.0	148.0	108.0	186.0	148.0	186		
L	212.0	212.0	212.0	205.0	212.0	275.0	205.0	455.0	275.0	692.0	455.0	990.0	692.0	990		
ISO 5211 MTG	F05	F05	F05	F05	F05	F05	F05	F07	F05	F10	F07	F14	F10	F14		
WT (Kg)	4.2	4.5	-	6.8	-	12.7	-	17.0	16.0	39.0	-	80.0	60.0	-		

Flow Path Diagram for Multiport Valves

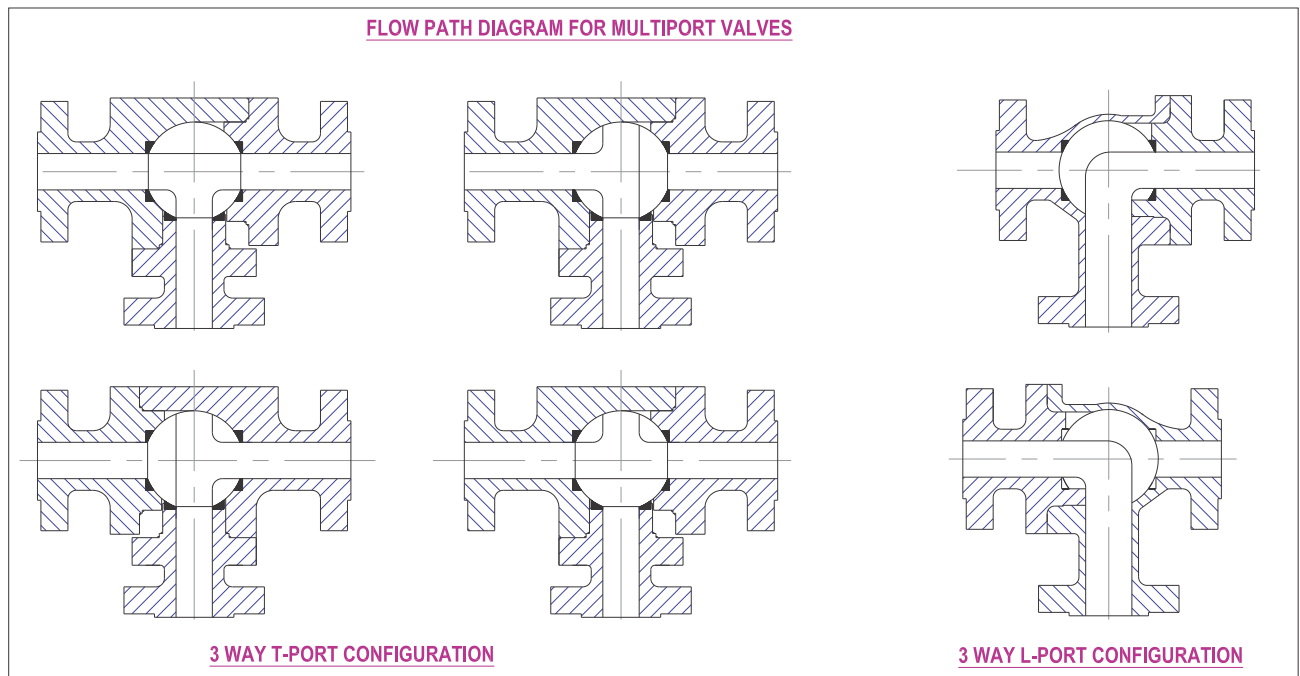

Automation

Pneumatic Actuators (Double acting or single acting) along with variety of accessories are provided for on-off or control duty applications. The valve Units are supplied duly mounted, Hooked & Calibrated with pneumatic actuators & accessories.

For automated valves fail close / open / stay put conditions are achieved using various accessories.

With Double acting actuators for fail / open / close requirements, volume tanks arrangements is supplied along with actuators.



Torque Values (Nm)

Torque Chart for Floating Ball Valves

Size (mm)		150 Class		300 Class			600 Class		900 Class	1500 Class
DP (Bar)		10	20	20	40	55	60	100	150	250
FB	RB									
15	20	4	5	5	7	9	15	20	25	35
20	25	6	8	8	9	12	20	30	35	45
25	32	10	12	15	18	20	30	45	70	115
32	40	15	19	19	22	25	45	70	100	160
40	50	20	25	25	28	30	75	90	140	180
50	65	30	40	40	45	50	95	130	200	300
65	80	35	45	55	65	70	110	150	320	450
80	100	55	70	75	100	110	130	200	435	600
100	150	110	130	165	175	180	280	370		
150	200	280	350	400	430	550	800	1000		
200	250	690	800	850	900	1000				

Notes:

- 1.0 These Torque values indicate Break Open Torque.
- 2.0 For Closing Torque values Multiply by 0.8.
- 3.0 For Run Torque Values Multiply by 0.45.
- 4.0 These Torque Values are based on clean Fluid.
- 5.0 For Dry Gas / Uncleaned fluid / Slurries applications Multiply by 1.2
- 6.0 For cryogenic application multiply by 2.5.
- 7.0 Above values are suitable for seat materials PTFE / RPTE/DEVELON/ NYLON. For seat material PEEK multiply by 2.0 for metal seat multiply by 4.0

ACTUATOR SIZING

Frist consider factor of safety for fluid conditions and seat MOC then,

- A. For selecting Gear Operator multiply by 1.5.
- B. For Selecting pneumatic or electric Actuator multiply by 1.3.



Komplek Ruko Intercon Plaza Blok D No. 9, Jl. Meruya Ilir raya , Srengeseng , Jakarta Barat 11630

Phone : 6221 5890 1302 Email : unggulpp@upp.co.id Web : www.unggulpp.com